

# **GRAVELY** **COMMERCIAL-10**



## **OWNER'S MANUAL**

 **GRAVELY**  
**TRACTORS**

GRAVELY LANE—DUNBAR—WEST VIRGINIA—U.S.A.

*A Division of Studebaker Corporation*

# SPECIFICATIONS

---

**Engine:** Gravely. One-cylinder, four-cycle, L-head type with removable head. Air cooled by centrifugal flywheel blower. Automatic compression release.

**Bore:** 3¼".

**Stroke:** 2⅞".

**Rings:** One oil ring, two compression rings.

**Valves:** Mechanical. Stellite exhaust valve seat. Positive rotor on exhaust valve.

**Carburetor:** Carter.

**Oiling System:** Splash.

**Magneto:** Flywheel.

**Air Cleaner:** Dry-type.

**Bearings:** Main bearings, precision ball.

**Horsepower:** 10 HP at 3600 RPM.

**Transmission:** Transmission and timing gears of alloyed iron and hardened steel. Precision cut teeth.

**Differential:** Automotive gear type, hardened steel cut beveled gears, steel worm gear, special alloyed bronze worm gear.

**Clutch:** Two double-acting cone-type clutches, one as speed selector, one for forward and reverse. Planetary gear system. Clutch bands bonded lining to heavy duty grey iron casting.

**Safety Clutch:** Power attachments individually protected from shock by safety clutch consisting of two fiber discs and one steel disc enclosed in spring-loaded driving plates. Discs slip under sudden shock; remain engaged to drive attachment at full horsepower under load.

**Height:** 28" (to top of hood.)

**Width:** 24" at widest point.

**Length:** 55" (without attachments.)

**Weight:** Net 475 lbs.

**Throttle:** with internal governor. Manual choke.

**Fuel Capacity:** 2 gallons.

**Engine Oil Capacity:** 3 pints.

**Transmission Oil Capacity:** 5 quarts.

**Tires:** 4.00x8, 16" outside diameter. Two-ply, sure-grip or diamond tread.

**Starter:** Electric starter-generator.

Form Number S-163-A

Dated: February 1967.

## OWNER'S EQUIPMENT RECORD

**Tractor Serial Number** ..... **Tractor Manufacturing Number** .....

**Identifying Marks Other Than Above** .....

**Carburetor Model Number** .....

**Purchased From** .....

**Gravely Representative's Telephone Number** .....

### EQUIPMENT LIST

**Description**

**Model Number**

**Description**

**Model Number**

## OPERATING INSTRUCTIONS



## COMMERCIAL-10 TRACTOR



### General Description:

The Gravely Commercial Tractor is a 10 HP., all-gear-drive, heavy duty tractor.

The Commercial Tractor is designed specifically for heavy duty commercial work. It is the heart of a complete power system of grounds maintenance, operating some 27 different tools and attachments. These attachments include a choice of five different Mowers, a Snowblower, Snow Plow, and a Riding Attachment.

In addition to these attachments, the Gravely Commercial Tractor also operates a Sprayer, Seeder-Spreader, Rotary Plow, Rotary Cultivator, Tool Type Cultivator, and many other general and specialized grounds maintenance tools.

Complete specifications are given on the facing page. A table of ground speeds and power take-off speeds is given on page 20 of these instructions.

### Lubrication:

Oil level for both engine and transmission should be checked daily.

**Engine** oil level is measured by a Dip Stick on the Engine. Use A.P.I. Service MS SAE 30 or SAE 10W30. Oil should be changed every 25 operating hours. See the Lubrication Chart, back page of this manual.

**Transmission** Capacity is five quarts. Keep filled to level shown on Dip Stick on Chassis. Tractor should be level when oil is checked.

The same type and grade of oil is used for both transmission and engine.

We recommend the transmission oil be changed every 120 hours. This cap is located forward under the hood of the Tractor.

### Fuel:

The Gravely Commercial Tractor uses any good grade of regular gasoline. Total tank capacity is approximately 2 gallons. It is filled conveniently by removing the gas tank Filler Cap which protrudes through the top of the hood. Fuel should be added to within about 1 inch of the top of the tank.

**CAUTION:** Never fill fuel tank while Tractor is running.

Wipe up all spilled gasoline before starting the engine.

### Attaching Attachments:

The Tractor must always have an attachment attached to the front, or an Attachment Boss Cover in place before the Tractor is started.

Safety Clutch for the attachments must be lubricated, which is done by splash lubrication from the transmission. Therefore, when changing attachments it is always wise to raise the attachment from the ground for a few moments by bearing down on the handles, to give any oil that might have collected in the advance casting an opportunity to drain into the chassis before changing attachments.

All front attachments are attached to the Tractor by two bolts and two nuts. Always be sure that the Power Take-Off Lever is in the "OUT" position before attaching an attachment.

**CAUTION:** Never attach or work around an attachment with the Tractor Engine operating. Always be sure that engine and attachment are completely stopped and ignition key is turned off before working around attachments.

Trail-behind attachments are attached to the Rear Hitch by a Split Socket, or one pin.

## Starting the Tractor:

Before attempting to start the Engine be sure that the High and Low Lever, Forward and Reverse Lever, and the Power-Take-Off Handle are in the neutral positions. Neutral positions are shown in Figure 1.

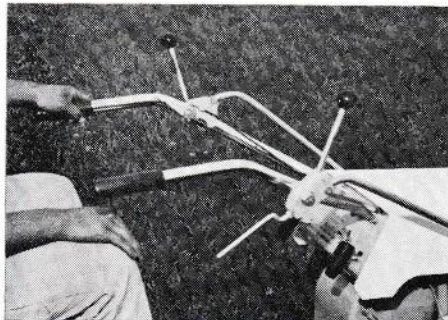

Figure 1

The Throttle is located on the left Handle as you stand or sit behind the Tractor. Push the Throttle down about one-third of its normal travel. Pull the Choke on the dashboard out. Turn the Ignition Key to the right or clockwise. This safety key opens the electrical circuit. Then depress the Starter Button until Tractor starts. Release the Button and push in the Choke.

The Gravelly 10 HP. Engine is fitted with an automatic compression release system which makes starting, even in cold weather, easy.

## Operating Controls:

Position and function of all of the controls are shown on the decal on the dashboard of the Gravelly Commercial Tractor. If in doubt refer to this diagram.

**HIGH AND LOW GEAR:** The large lever on the outside of the

left Handle operates the high and low gears. When in a near-upright position the High and Low Gear Lever is in the neutral position. To put the Tractor in high gear, push it forward until it locks. See Figure 2.

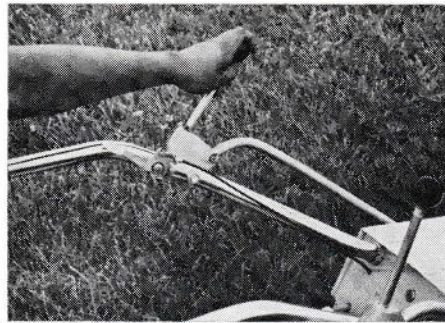

Figure 2

Pulling this lever back (towards the operator) and locking it puts the transmission in low gear. This lever may be operated independently from the forward and reverse gear lever. It may be moved from either position to the other at any time during operation of the equipment.

**POWER TAKE OFF HANDLE:** Power attachments must be placed in gear with the High and Low Lever OUT of gear (in neutral). To put the attachment in gear, grasp the Power Take-Off Handle as shown in Figure 3, and pull back until it locks in the proper position.

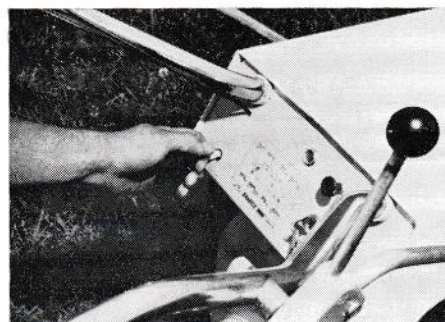

Figure 3

Since the Gravelly Tractor is driven by an all-gear-drive direct from the Crankshaft of the Engine, and connection is made to the attachment through a splined steel shaft and a dog-clutch. Exces-

sive repairs and maintenance can be prevented by using care in putting attachments in gear. The best procedure is to have the High and Low Gear Lever in neutral, the engine throttled down to a medium idle, pull back on the Forward-And-Reverse Lever until the Engine "pulls down" slightly, then operate the Power Take-Off Handle. This use of the reverse gear simply slows the speed of the shaft and allows the dog clutch to go in gear easily and without excessive clash.

**FORWARD and REVERSE:** The Gravelly Commercial Tractor has a unique instant forward and reverse planetary clutch operated by a unique lever system that gives you instant control of the Tractor, under any conditions.

After the High and Low Lever has been put in the proper gear, and the attachment has been put in operation, operation of the Forward and Reverse Lever is the next step.

This lever is located on the right Handle of the Gravelly Commercial Tractor. It consists of a lever with a ball handle and another plain, bar type lever protruding from the gear handle casting at approximately 120 degrees.

To go forward, grasp the Ball on the Lever and move it forward until it locks in forward position. Feed fuel by throttle as required. See Figure 4.

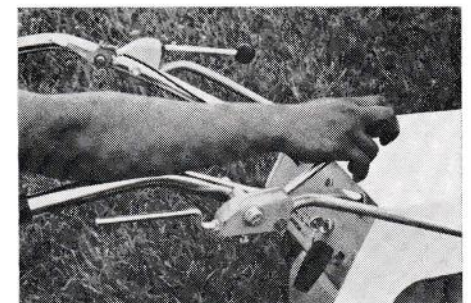

Figure 4

To stop the forward motion of the Tractor simply strike the plain

lever with the edge of the hand and the spring loaded lever will jump into neutral. See Figure 5.

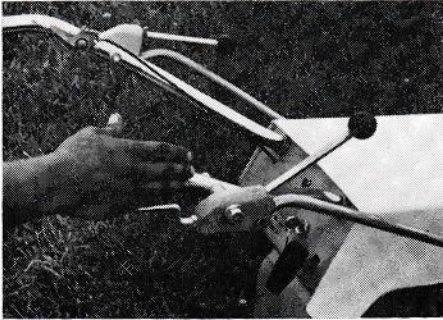

Figure 5

If desired, the operator can also reach forward, get the Ball Handle and pull it into the neutral position. However, striking the plain lever is a very fast and efficient method of taking the Tractor into neutral gear instantly. This plain lever is also useful in a trimming situation and is also a convenience in starting out.

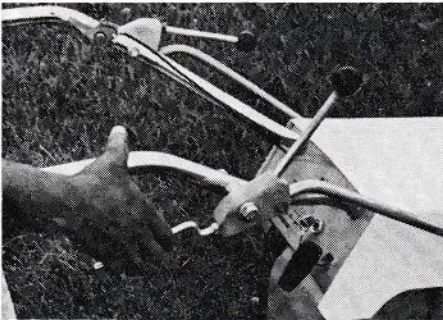

Figure 6

The plain lever may be used to ease the Tractor into gear by pulling up on it slowly until the gear is locked into the forward position. Trimming work, or where ground speed needs to be reduced to a minimum for maximum control, use this lever to "slip" the planetary clutches reducing the ground speed and giving very precise control of the Tractor.

To put the Tractor in reverse simply grasp the round handle and pull it back or towards the operator. This is a safety-type reverse, and requires pressure on this handle to keep the Tractor moving in

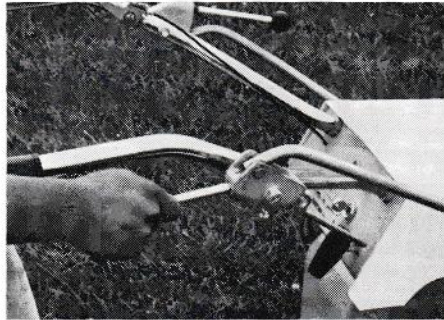

Figure 7

reverse. Releasing the handle permits it to return to neutral instantly.

**SWIFTAMATIC 8 TRANSMISSION:** The Gravelly Commercial Tractor is equipped with the Swiftamatic 8 transmission. This is an all-gear-drive transmission which allows the operator to select 4 forward or 4 reverse speeds.

This is accomplished by selecting either high or low gear by means of the left handle lever and also an optional selection of speed ranges by operating the Swiftamatic Handle Control. The Swiftamatic transmission, when in the low range, reduces the ground speed by 1/2 without affecting attachment speed. Conversely, in high range it increases the ground speed 100% from the low range.

In normal operation, the speed range to do the job is selected before forward and reverse levers are operated to move the equipment. Selection is made by moving the right pistol-grip handle in or out. **IN** is low range, **OUT** (towards the operator) is high range.

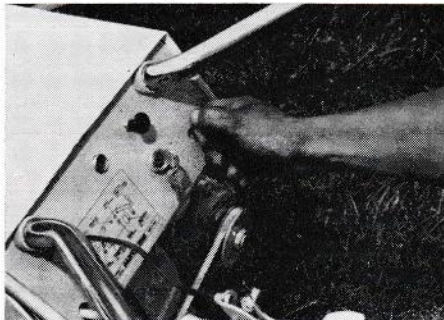

Figure 8

**GENERATOR LIGHT:** The dashboard also contains a gener-

ator indicator light. When it glows red, with engine running at working speed, the generator is not functioning efficiently, and the generator should be serviced. It may glow or flicker when engine idles, but this is normal.

**GOVERNOR THROTTLE:** The Gravelly Commercial Tractor has an integral Governor, and fuel is automatically fed to the engine as required from a setting obtained by operating the Governor Throttle Lever on the left handle.

To **increase** engine speed, press the throttle handle down.

To **reduce** speed, move the handle up.

Normal operating speed for maximum performance is at about 2/3 throttle.

#### **SERVICING THE AIR FILTER:**

The Gravelly Commercial Tractor is equipped with an over-size heavy duty air cleaner. This cleaner has a paper filler and is so constructed that it must be serviced when required because when the filter is filled with dirt and dust particles, it will starve the engine for air which makes a noticeable difference in performance.

If your Gravelly Commercial Tractor appears to be losing power and performance, the first thing to check is the Air Filter. To service, simply remove the cover, remove the filter element and replace with a new filter element.

Since Gravelly Commercial Tractors are used in many different applications, it is almost impossible to set a given time for servicing the Air Filter. Under normal operating conditions, the Air Filter should serve the Tractor from 40 to 80 operating hours before needing replacement. In very dusty and dirty conditions it is possible that it will be necessary to change the filter more often. Routine inspection of the filter should be made each day before the unit is

operated and the filter serviced if required.

**CAUTION:** Do not attempt to by-pass the filter element by punching holes in it, or otherwise disturbing the surface of the air filter filler. Any break in the air filter surface will allow dust and dirt to enter the engine which will cause excessive repairs.

**WARNING:** Gravely warranty on the Commercial Tractor is automatically voided if the air cleaner has not been properly serviced, or the filter surface has been broken by the operator.

### Routine Maintenance:

The Tractor and Attachments in use should be inspected daily, bolts tightened where required, oil level in both Engine and Transmission checked, Air Filter checked, and a general visual inspection given of the unit. The Gravely Commercial Tractor is normally used under rough and rugged conditions, thus subjected to more shock and strain than normal equipment. For this reason, particularly during the first three months of operation, this inspection of the equipment should be held each morning before the equipment is put into operation.

### Tire Pressure:

The tires should be inflated to a pressure of 12 pounds.

### Operating Hints:

The Gravely Commercial Tractor is the result of some 50 years experience in the specialized manufacturing of heavy duty small power equipment. It has been designed and tested under the most rugged conditions. Due care has been taken to make the equipment as safe and as easy to operate as is humanly possible.

The first and most important thing about the equipment is to familiarize the operator with the controls. They are simple and easy to learn and to operate, and there

is a quick reference decal on the dashboard showing position and function.

Second, the operator should realize that this is a very powerful piece of equipment and deserves to be treated with respect. It is much stronger than the operator, and pitting the operator's strength against the tractor's strength is a useless duel. The best way to operate the Gravely equipment is expressed by an old phrase "let the tractor do the work." The function of the operator is simply to operate the controls and to guide the Tractor through its various maneuvers. A few hours practice with the Gravely Tractor and most operators find the simple, safe controls, the automotive type transmission, and the balance and responsiveness of the unit make it a pleasure to work with.

There are certain optional accessories that can help the operator under special conditions. One of the virtues of the Gravely Commercial Tractor is its ability to work on steep slopes safely. This is due to its low center of gravity. However, on very steep slopes, we recommend the use of optional Dual Wheels which increase the traction of the Tractor and also assist in its stability. With the use of Dual Wheels it is not uncommon for Gravely tractors to operate on a 60% slope.

The Rider can be very useful. Particularly in large area mowing. A Rider should be available to the operator to allow him to do the job more efficiently and comfortably.

This Rider can be dropped by pulling one pin and the Tractor then used as a walking Tractor for the rough and rugged places, where it would not be safe to ride. It can also be used on jobs where close trimming and control is required and it is able to get into places in which larger tractors cannot operate.

## SAFETY CLUTCH

Each power attachment has a Safety Clutch which stalls the attachment when an obstacle is hit, preventing damage to both the Tractor and attachment.

The Clutch is properly adjusted when there is a .025-inch gap between coils of the springs around the six bolts of the Clutch. Check the gap periodically with a feeler gauge.

To decrease the gap, tighten the bolts; to increase the gap, loosen the bolts. If excessive slippage is encountered after adjusting to .025-inch, decrease the gap to .020-inch.

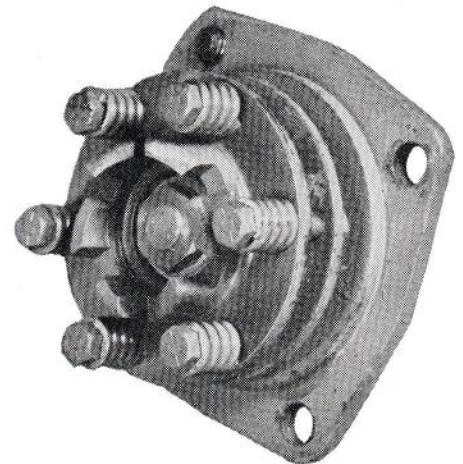

Safety Clutch Figure 9

## Gravely Power Attachments

The Drive Assembly of each power attachment is attached to the front of the Tractor by two bolts and two nuts. When attaching, tighten securely one of the top nuts before tightening the other nuts and bolts. When detaching, remove completely both bottom bolts and one of the top nuts before removing the other top nut.

When attaching, be sure the Engine is stopped and the Attachment Clutch Control is at the OUT position. The Tractor and attachment should be on level ground. To keep the Tractor from moving, the Operating Levers may be engaged, but both must be returned to neutral when the Tractor is started.

# 50-INCH ROTARY MOWER

## LUBRICATION

Check the oil level in the Gear Housing every four hours of operation, by removing the Oil Level Plug, 1 in Figure 10. If oil runs out, the oil level is all right; if not, oil must be added.

To add oil, remove the Oil Filler Plug, approximate location shown by 2 in Figure 10, and pour oil through the Oil Filler Hole. Stop when oil begins to run out the Oil Level Hole. Replace both plugs before mowing.

Use SAE 140 in the Gear Housing.

Use General Purpose Grease every 10 hours in the grease fittings on the Caster Brackets, Caster Wheels, and Swivel Casting, 3 in Figure 10.

Use General Purpose Grease every 10 hours in the grease fitting on each Spindle Assembly. **Note:** The Spindle Assembly grease fitting is vented to make it impossible to over-lubricate the Spindle Assembly. While greasing, if you observe grease coming out the vent, this means simply that the Spindle Assembly is loaded to capacity with grease.

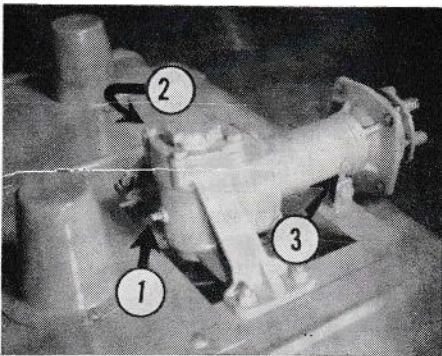

Figure 10

## CUTTING HEIGHT ADJUSTMENT

Cutting height adjustment is made at the Spindle Assemblies on the Spindle Shafts.

Each of the three Blades can be adjusted to cut from one to four inches from the ground. At delivery, the cutting height is set at 2½ inches from the ground. To adjust each Blade:

1. Remove the Spindle Cover (the cylindrical cover on top of the Belt Guard) by removing the sheet metal screws which hold it to the Deck.

2. Remove the cotter key from the end of the Height Adjustment Pin, 1 in

Figure 11. On the center and right Blades (center and right as you stand at the Handles) the cotter key and Pin are accessible upon removal of the Spindle Covers. However, to gain access to the left Blade cotter key and Pin, reach under the left Belt Guard. An alternate method is to remove the entire left Belt Guard (which includes the Spindle Cover) by unscrewing the machine screws which hold it to the Deck.

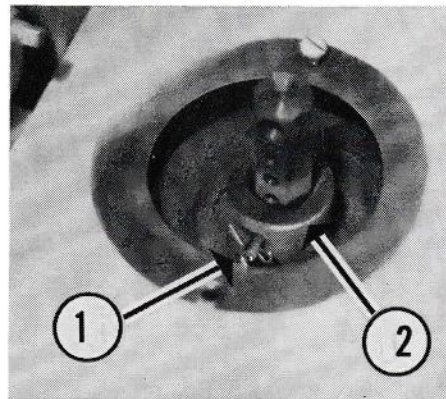
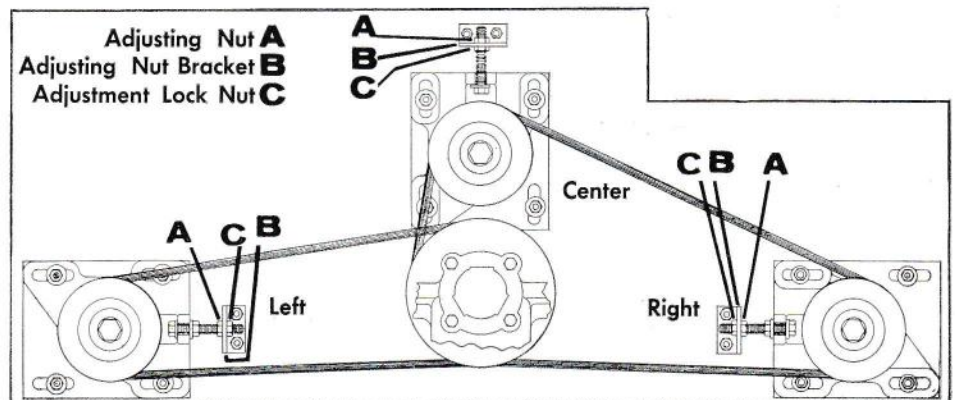

Figure 11

3. Insert a screwdriver or similar tool in the large hole at the top of the Spindle Shaft. Using the screwdriver, lift up slightly on the Shaft and remove the Pin.

4. There are six holes in the Shaft (exclusive of the large hole in which the screwdriver was placed) which regulate the cutting height. The topmost hole sets the cutting height at 1½ inches from the ground, the next at two inches from the ground, and so on in ½-inch increments to a maximum cutting height of four inches. Line up the hole corresponding to the desired cutting height with the holes in the Shaft Housing, 2 in Figure 11, and insert the Height Adjustment Pin into these. Then insert the cotter key in the end of the Pin.

5. Replace the Spindle Covers (and the left Belt Guard, if it has been removed).



## CUTTING PLANE ADJUSTMENT

The Caster Wheels keep the Mower in a horizontal plane parallel to the ground. When the Caster Wheels are adjusted properly and the three Blades are set at the same cutting height, the Mower cuts smoothly and uniformly throughout its swath.

During operation, should you notice the Mower cutting closer on one side of its swath than on the other, or if the Skids mark the ground with a narrow trench-like depression, this would indicate the Caster Wheels are out of adjustment.

To rearrange the washer combination, place a block under the Skid nearer the Caster with which you are working. Then remove the bolt which secures the Caster Fork to the Caster Bracket. Remove the Caster Wheel and Fork and rearrange the washers as desired. Then reassemble the entire Caster Assembly.

## BELTS

**BELT ADJUSTMENT.** The Belts are in proper adjustment when the Mower is delivered. Loosening is seldom required, except when replacing a Belt. However, from time to time you will need to tighten the Belts; this is indicated by the Mower skipping over areas within its swath.

The left Belt is adjusted at the left Spindle Assembly, access to which is gained by removing the machine screws which hold the left Belt Guard to the Deck. The right Belt can be adjusted at either the right or center Spindle Assembly, access to which is gained by removing the machine screws which hold the center and right Belt Guards to the Deck. We recommend that adjustment of the right Belt be made at the right Spindle Assembly initially; only if additional adjustment is needed should you adjust at the center Spindle Assembly.

**Note:** In adjusting the Belts it is possible to pull a Spindle Assembly far enough from its proper position to cause its Blade to strike the adjacent Blade while mowing. When you have adjusted the Belts, always rotate the Blades by hand to make sure there is no Blade interference and to insure there is sufficient overlap to keep from missing areas, especially on turns.

The procedure for tightening each Belt is the same—the Spindle Assembly is moved from the Main Drive Pulley as follows (Refer to Figure 12 for parts identification):

1. Loosen the four nuts which hold the Spindle Assembly and Dust Shield to the Deck. It is not necessary to hold the bolts onto which these are screwed, as they are locked to the underside of the Deck.

2. Back off the Adjustment Lock Nut several turns from the Adjusting Nut Bracket.

3. Tighten the Adjusting Nut against the Adjusting Bracket until proper tension has been applied to the Belt. When the Belt is in proper adjustment, by applying moderate pressure at its midpoint, you should be able to deflect the Belt approximately 1/2-inch.

4. Holding the Adjusting Nut firmly against the Adjusting Nut Bracket, tighten the Adjustment Lock Nut securely against the Bracket.

5. Tighten firmly the four nuts which hold the Spindle Assembly and Dust Shield to the Deck.

In loosening a Belt, the Spindle Assembly is moved toward the Main Drive Pulley as follows (Refer to Figure 12 for parts identification):

1. Loosen the four nuts securing the Spindle Assembly and Dust Shield.

2. Back off the Adjusting Nut several turns from the Adjusting Nut Bracket.

3. Back off the Adjustment Lock Nut from the Adjusting Nut Bracket until proper Belt tension is reached.

4. Holding the Adjustment Lock Nut firmly against the Adjusting Nut Bracket, tighten the Adjusting Nut firmly against the Bracket.

5. Tighten firmly the four bolts securing the Spindle Assembly and Dust Shield to the Deck.

**BELT REPLACEMENT.** After all possible Belt adjustment has been made, if the Mower continues to skip over areas within its swath, replacement of the appropriate Belt is indicated.

To replace the right Belt (right, as you stand at the Handles):

1. Following "Belt Adjustment" procedures, remove the center and right Belt Guards and move the center and right Spindle Assemblies toward the Main Drive Pulley as far as possible.

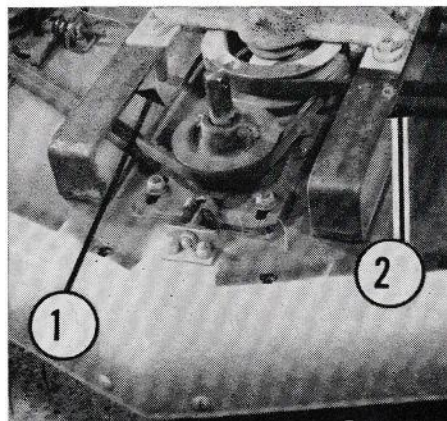

Figure 13

2. Remove the right Drive Mount Support Sleeve, 1 in Figure 13. To do this, elevate the Mower sufficiently to enable you to hold the Sleeve Bolt on the underside of the Deck. Remove the nut from the Sleeve Bolt, tap the Bolt free of the Mower, and remove the Sleeve.

3. Slip the Belt from the Main Drive Pulley, Center Spindle Pulley, and right Spindle Pulley, and remove the Belt from the Mower.

4. Place the new Belt on the Pulleys. Replace the right Drive Mount Support Sleeve.

5. Adjust the Belt. When positioned properly on the Pulleys and in proper adjustment, there should be approximately 1/32-inch between the top of the Belt and the top of the Pulley flanges.

6. Replace the Center and Right Belt Guards.

To replace the left Belt (left, as you stand at the Handles):

1. Remove the left, center, and right Belt Guards.

2. To provide clearance for removing the left Belt, the right Belt must be loosened enough to slip it from its groove in the Main Drive Pulley. Normally, the right Spindle Assembly can be moved far enough forward toward the Main Drive Pulley to make this possible. Do not move the center Spindle Assembly unless absolutely necessary. Do not remove the right Drive Mount Support Sleeve.

3. Move the left Spindle Assembly as far forward as possible toward the Main Drive Pulley.

4. Remove the left Drive Mount Support Sleeve, 2 in Figure 13.

5. Slip the Belt from the left Spindle Pulley and Main Drive Pulley, removing it from the Mower.

6. Place the new Belt on the Pulleys and replace the left Drive Mount Support Sleeve.

7. Adjust the Belt. Be sure there is approximately 1/32-inch clearance between the top of the Belt and the top of the Pulley flanges.

8. Make sure the right Belt has been replaced on the Main Drive Pulley and is in proper adjustment before replacing the three Belt Guards.

### BLADE SHARPENING

To sharpen a Blade, remove it from the Mower and use the original cutting edges as your guide. After sharpening, test for proper balance by inserting a screwdriver and holding the screwdriver parallel to the ground. If one side of the Blade dips noticeably, that side is too heavy and should be ground further.

### OPERATION

We recommend that you mow so the cut grass is discharged (out the left side of the Mower) onto the lawn areas which have not been cut.

### CAUTION

Never put your hands or feet under the Deck while the Mower is running, or for an interval after the Mower has been disengaged. Make sure all Blades have stopped before attempting any repair or adjustment to the Mower, and that the attachment is disengaged and the Engine stopped.

## COMMERCIAL 40 ROTARY MOWER

### ATTACHING

The mower is attached to the front of the tractor by two bolts and two nuts. When attaching, tighten securely one of the top nuts before tightening the other two bolts and nut. When detaching the mower from the tractor, remove completely both bottom bolts and one of the top nuts before removing the other top nut.

When attaching, be sure the engine is stopped, and ignition key is turned off, the attachment clutch lever is at the "OUT" position and the operating levers are in the neutral position.



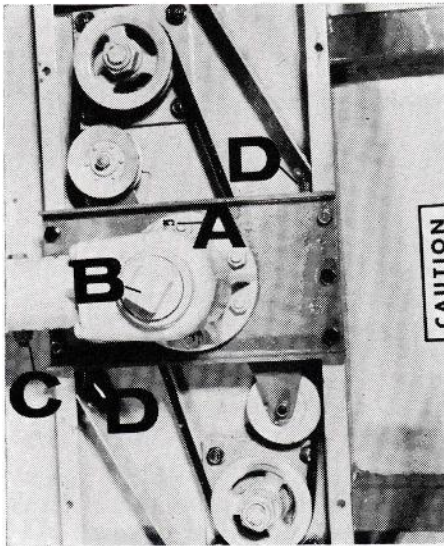

Figure 14

### SWIVEL ACTION ADJUSTMENT

The swivel action of the mower is regulated by the bolt and nut on the Swivel Casting. (C, Figure 14) The nut should be tightened until there is no swivel at all to the mower. The nut should then be loosened just enough to allow the mower sufficient swivel action to follow the ground contour under its own weight.

### LUBRICATION

Check the gear housing oil level every four hours of operation by removing the oil level plug shown at A, Figure 14. If oil runs out, the oil level is all right, if not, oil must be added until the proper oil level is obtained.

To add oil, remove the oil filler plug shown at B, and pour through the hole until oil begins to run out the oil level hole. Replace both plugs before operating the mower.

Use SAE 140 lubricant. Use a good grade of general purpose grease occasionally in the grease fitting of the swivel casting.

Blade spindles should be lubricated every 10 hours of service with general purpose grease. Apply lubricant through the grease fitting until lubricant starts to come out the vent hole on the opposite side of the spindle.

No lubrication is required for the two belt tightening idler pulleys.

### BELT ADJUSTMENT

None required. Belts are tensioned automatically by spring-loaded idlers.

### BELT REPLACEMENT

Remove both belt covers.  
Detach one end of each idler tension spring. (D on figure 14)

Remove belts from around blade spindle and idler pulleys.

Remove the two nuts and three bolts holding the drive mounting plate to the deck. Remove the drive and belts.

Replace belts by reversing the above procedure.

Put new belts on drive pulley **before** re-attaching drive plate to mower.

### CUTTING HEIGHT ADJUSTMENT

The cutting height of the mower is adjusted by the collars on the rotor shaft. The closer the blades are to the bottom of the deck, the higher the cut, and vice versa. Vary the combination of the three collars as you desire.

### CAUTION

Never put your hands or feet under the deck of the mower while the mower is running, or for an interval after the mower is shut off. Make sure the blades have stopped completely before putting your hands or feet under the deck.

### CASTER WHEEL ADJUSTMENT

Caster wheels keep the mower in a horizontal plane parallel to the ground. If the mower cuts closer on one side than it does on the other, or if the skids mark the ground, the caster wheels should be adjusted. Adjustment

## ATTACHMENTS USING 30-INCH ROTARY MOWER DRIVE

In addition to the 30-inch Rotary Mower, other power attachments use the Drive Assembly. These are the Leaf Mulcher, Leaf-Away and Circular Saw.

### LUBRICATION

Check the Gear Housing oil level every four hours of operation by removing the Oil Level Plug (lower, small plug). If oil runs out, the oil level is all right; if not, oil must be added.

To add oil, remove the Oil Filler Plug (on top of mower housing), pour through the Oil Filler Hole until oil begins to run out the Oil Level Hole. Replace both Plugs before operating.

Use SAE 140 in the Gear Housing.

is accomplished by removing "hairpin" from the top of the fork, and re-arranging the spacing washers as required.

To replace wheels, remove elastic stop nut and remove the axle bolt, replace with new wheel by reversing the procedure.

### REMOVABLE DECK SIDE

The mower is equipped with a removable side which can be removed when mowing high, heavy weeds, or thick tough grass of considerable height, which will give better mowing results.

### CAUTION

It is recommended that this side not be removed unless absolutely necessary. When this is done, there is the danger of rocks, tin cans, metal objects, etc., being thrown from under the hood. Never mow with the side removed in public places or where persons or property can be injured or damaged by materials thrown from under the hood.

### BLADE SHARPENING

Use a file or grindstone to sharpen the blade. Try to follow the same bevel as the originally sharpened cutting edge, although the precise degree of the bevel is not critical.

### REMOVING THE BLADES

Use a standard 3/8 socket drive in the square hole in the bottom of the rotor shaft to hold the shaft while removing the blade nut.

Use General Purpose Grease occasionally in the grease fittings of the Swivel Casting.

### SWIVEL ACTION ADJUSTMENT

Swivel action of the Drive Assembly is regulated by the Swivel Adjustment Bolt and Nut on the Swivel Casting. Loosening the Adjustment Nut increases swivel action; tightening it decreases swivel action. When using the 30-inch Rotary Mower, Leaf Mulcher, and Leaf-Away, there should be sufficient swivel action to allow the attachment to follow the ground contour with its own weight. When using the Circular Saw, loosen

the Adjustment Nut, turn the Drive Assembly to the desired angle, and tighten the Nut firmly.

## 30-INCH ROTARY MOWER

To attach the 30-inch Rotary Mower to the Model 106 Drive Assembly, detach the Drive Assembly from the Tractor and turn it upside down so the Oil Filler Plug is on the bottom. **Note:** This is a Vented Plug, to keep oil from running out, plug with a matchstick until mower is assembled.

Next, set the Mower Hood in place with the Rear Fender (the taller of the two Fenders) facing the rear of the Drive Assembly.

Place a bolt and plain 1/2-inch washer through each of the six holes in the Hood and Gear Housing flange, with the bolt heads on the under side of the Hood. Place a lock washer and nut on the end of each bolt showing through the Gear Housing flange and tighten each nut securely.

Place the Collars and Blade onto the Rotor Shaft. (See "Cutting Height Adjustment," below.) Tighten the nut on the end of the Rotor Shaft securely. **Note:** The Gravely Triple-Purpose Wrench, available from your Gravely dealer, is required for the nut on the end of the Rotor Shaft. It also must be used for the Actuating Lever Nut on the Sickle Mower, and Tine Shaft Nut on the Rotary Cultivator.

Special counter-weights are available to increase weight of Rotary mower if desired.

### CUTTING HEIGHT ADJUSTMENT

Cutting height is adjusted by the Collars on the Rotor Shaft. The closer the Blade is to the Gear Housing, the higher the cut, and vice versa. Vary the Collars as you desire, always making sure the counter-bored sides of the Collars face the Blades.

### BLADE SHARPENING

Use a file or grindstone to sharpen the Blade. Try to follow the same bevel as the originally-sharpened cutting edge, although the precise degree of bevel is not critical.

### FENDER ADJUSTMENT

When mowing short weeds and lawns, the Front Fender (the smaller Fender) must be on front of the Mower Hood, and the Rear Fender (the larger Fender) on the rear.

However, when mowing high, heavy brush, or thick, tough grass of considerable height, better mowing results will be obtained by removing the Front Fender, and replacing it with the optional Chain Guard. See below.

### CHAIN GUARD

When the Front Fender is removed, it must always be replaced with the optional Chain Guard. Attached to the Mower by bolts in place of the Front

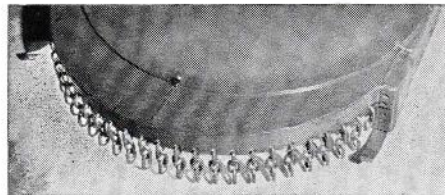

Chain Guard Figure 15

Fender, the chains reduce the velocity of materials that may be thrown out. It is available from your Gravely dealer.

### CAUTION

Never put your hands or feet under the Hood while the Mower is running, or for an interval after the Mower is shut off. Make sure the Blade has stopped completely, with the Engine off and the Mower disengaged before attempting any adjustment or repair to the Mower.

- Never operate the Mower unless the Front Fender or optional Chain Guard is on the front of the Mower, and the Rear Fender is on the rear of the Mower.

- When using the 30-inch Rotary Mower, never shift the Inside Operating Lever directly from high to low. Always pause momentarily in neutral, giving the Blade a chance to slow down naturally, thus avoiding the severe braking action from a sudden shift into low gear.

## LEAF-MULCHER

Attach the Leaf Mulcher to the 30-inch Rotary Mower as follows:

1. Remove both the Front and Rear Fenders. Bolt the Rear Fender to the front of the Mower Hood.
2. Attach the Leaf Mulcher to the rear of the Mower Hood, in the position normally occupied by the Rear Fender.

To operate the Leaf Mulcher, proceed the same as you would in mowing. Normal walking speed is usually adequate to do a good job, although when leaves are wet or packed down, you may have to go over the area twice.

## LEAF-AWAY

Instructions for assembling and attaching are packed with the Leaf-Away.

### MUFFLER ADJUSTMENT

Remove the Muffler, insert the all-thread Nipple and Elbow, and re-attach the Muffler. Direct the Muffler so the exhaust will hit the asbestos panel on the Pouch. When the Leaf-Away is not being used, the Nipple and Elbow may be removed, and the Muffler placed on the Tractor in the normal manner.

### EMPTYING POUCH

To empty the Pouch, simply unstrap the Pouch from the Chute, unhook it from the Pouch Support, and unzip. Contents are easily shaken out.

**Note:** For use in large areas, such as college grounds, we recommend purchase of additional Pouches. Several filled pouches may be taken in a truck to where the leaves are to be burned.

### OPERATING HINTS

- Operate the Leaf-Away with the Tractor in high gear at all times.

- Stoppage caused by leaves and debris blocking the Chute is detected by collapse of the Pouch. To correct, keep the Blowers operating at high speed and work the Chute Cleaner Poker with a vertical motion into the Chute.

- Although the Leaf-Away will function effectively in most cases with only one Mower Blade Blower, we recommend use of both Blowers, especially where leaves and debris have a high moisture content. Also, we recommend you clean your lawn often enough to prevent leaves from becoming packed down by heavy rain or snow, as leaves in this condition increase the chance of Chute clogging.

## CIRCULAR SAW

Attach the 18-inch Circular Saw to the Drive Assembly as follows:

1. Remove the Collars and nut from the Rotor Shaft.
2. Place the Collars onto the Shaft with the counter-bored sides facing the end of the Shaft. Put the Circular Saw on the Shaft, and then the collars, with the counter-bored side facing the Saw. Tighten the nut securely. **Note:** Cutting edges of the Saw teeth must face in the direction of Shaft rotation.

## OPERATING HINTS

Feed the Circular Saw from the side, just as you would feed the Chain Saw, by exerting slight pressure on the Tractor Handles. Do not force the Saw; let it "eat" into the tree gradually.

- The Circular Saw is most effective for clearing land of saplings, sprouts, and other small growth.

- Drive the Tractor slowly, swinging the Saw slightly from side to side to clear a wider path. Experience will dictate when it is best to stop your forward motion and concentrate on a sprout or sapling too large to "drive through."

- Be careful not to run the Saw into the ground or against rocks.

## OPTIONAL SAW GUARD

An optional Circular Saw Guard, which attaches to the Gear Housing by a split ring, is available from your Gravely dealer. When ordering, give the model number of your Drive Assembly.

## SHARPENING THE SAW

We do not recommend field sharpening. Have this done by someone specializing in circular saw sharpening, or by your Gravely dealer.

## STORAGE

When the Circular Saw is to be stored for several days or longer, we recommend you coat it heavily with General Purpose Grease.

## 30-INCH REEL MOWER

The 30-inch Reel Mower gives a smooth and uniform cut every time. For the larger mowing jobs, 25-inch Gang Units may be attached to both sides to provide a 75-inch swath.

## LUBRICATION

Check the Gear Housing oil level every four hours of operation by removing the Oil Level Plug, 1 in Figure 17. If oil runs out, the oil level is all right; if not, oil must be added.

To add oil, remove the Oil Filler Plug, 2 in Figure 17, and pour through the Oil Filler Hole until oil begins to run out the Oil Level Hole (too much oil will cause over-heating and consequent gear damage). Replace both Plugs before resuming mowing.

SAE 140 is recommended.

Change oil in the Gear Housing at least annually. To drain, remove the entire Strut Casting, 3 in Figure 17; replace after the oil has drained. Add oil as instructed above.

Use General Purpose Grease occasionally in the grease fittings on the Swivel Casting, 4 in Figure 17, and as required in the grease fittings for the Reel Bearings, arrow in Figure 18. It is important to lubricate properly the Reel Bearings, as the grease forms a water seal around each Bearing, preventing rust. Use General Purpose Grease as required in the grease fittings on the Roller Bar.

## CUTTING HEIGHT ADJUSTMENT

Turn the Height Adjusting Screw, 5 in Figure 17, clockwise to raise the cutting height; turn it counter-clockwise to lower the cutting height.

## REVERSE LAPPING OF REEL

The Mower has a special reverse which permits lapping the Reel against the Bed Knife, eliminating in some cases grinding the Reel. The Reel should be lapped any time the adjustment of the Reel against the Bed Knife is changed radically. To lap the Reel:

1. Loosen the bolt on the front of the Gear Housing, 6 in Figure 17.

2. Slowly roll the Reel back and forth with one hand, pushing the bolt to the opposite side of the Gear Housing with the other. This engages the reverse; when fully engaged, tighten the bolt.

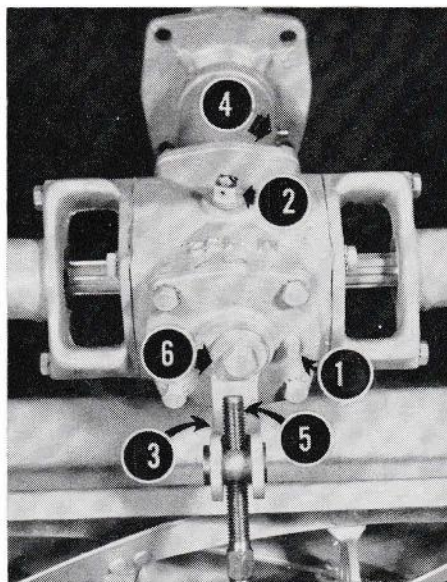

Figure 17

3. With the Mower running at normal speed, carefully use a paint brush to apply a 60-grit lapping compound to the Reel. Allow the Reel to lap in reverse until it makes good contact with the Bed Knife Bar along its entire length.

To put the Reel back into forward, use the above procedure, except push the bolt to the right and lock by tightening.

## REEL ADJUSTMENT

The Reel must be adjusted properly for the Mower to do a good job.

To test Reel adjustment, place a sheet of paper between the Reel and Bed Knife Bar and turn the Reel by hand. Perform this test at several points along the Bar.

If the paper is cut cleanly each time, the Reel is in proper adjustment. If not, the adjustment is too loose and must be corrected by moving the Reel closer to the Bed Knife Bar. **Note:** If the Reel contacts the Bar (this will seldom occur), the adjustment is too tight and must be corrected by moving the Reel away from the Bar.

The Reel is adjusted by the Adjustment Lock Nut, 1 in Figure 19, and the Reel Adjusting Bolt, 2 in Figure 19. To move the Reel closer to the Bar, loosen the Adjustment Lock Nut and turn the Reel Adjusting Bolt counter-clockwise; to move it from the Bar, turn the Reel Adjusting Bolt clockwise.

Adjustment can be made at either side of the Reel. If, for example, facing the Reel you find the paper is not cut cleanly on the right side, loosen the Adjustment Lock Nut on the right side and turn the Reel Adjusting Bolt counter-clockwise. Then loosen the Adjustment Lock Nut on the left side and turn the left Reel Adjusting Bolt clockwise slightly. Test. Repeat if necessary. Tighten the Adjustment Lock Nuts to hold the adjustment.

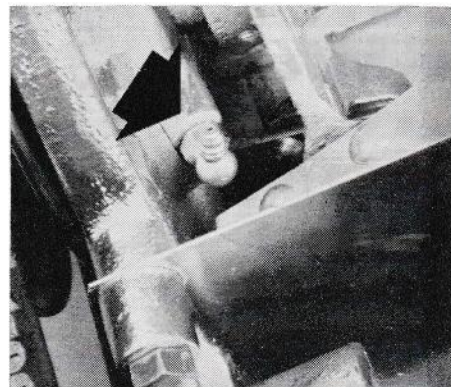
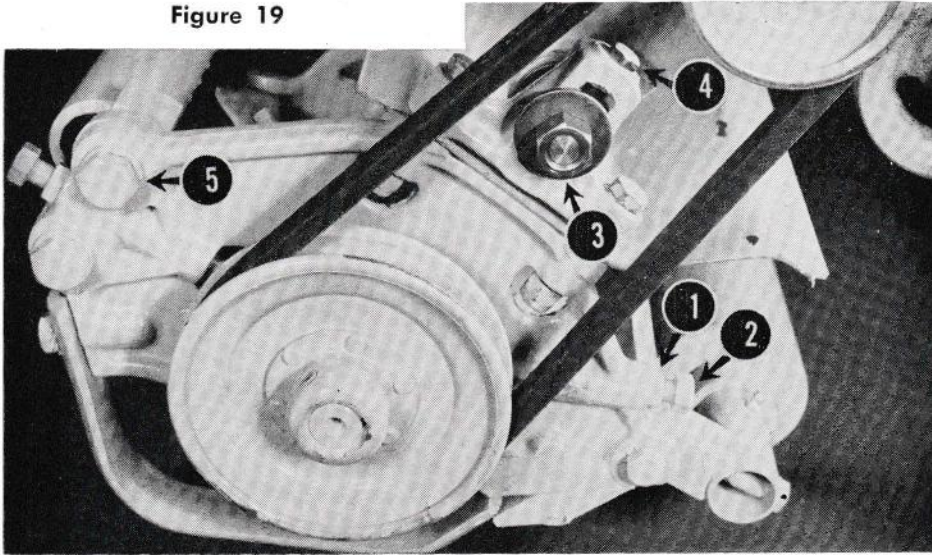

Figure 18

Figure 19



### BELTS

Power is transmitted from the Gear Housing to the Reel by means of a V-Belt at each end of the Reel.

**ADJUSTMENT.** Both Belts are in proper adjustment when moderate pressure applied to the mid-point of each Belt will deflect it approximately one inch.

To tighten a Belt, loosen the Belt Adjusting Nut, 3 in Figure 19, and turn the Belt Adjusting Bolt, 4 in Figure 19, clockwise. To loosen, turn the Adjusting Bolt counter-clockwise. After proper adjustment is reached tighten the Adjusting Nut.

If the Adjusting Bolt has been turned clockwise as far as possible and the Belt does not tighten, the Belt should be replaced.

**INSTALLATION.** To install a new Belt, turn the Height Adjusting Screw until it releases the Reel Assembly from the Gear Housing Strut. Raise the Mower slightly and swing the Reel toward the Tractor until the Belts are loose on the Pulleys. Remove the old Belt and replace with the new one. With the new Belt in place, return the Reel Assembly to the normal position, replace the Height Adjusting Screw, and adjust the Mower to the proper cutting height.

Make sure the newly-installed Belt is in proper adjustment.

## 25-INCH GANG UNITS

The first step in attaching the 25-inch Gang Units to the 30-inch Reel Mower is to attach the Power Take-off to the Swivel Casting (of the Drive Assembly) as shown in Figure 20.

Next, a Belt for each Gang Unit must be attached to the Power Take-off as follows:

1. Remove the Belts from the 30-inch Reel Mower, following procedures outlined above.

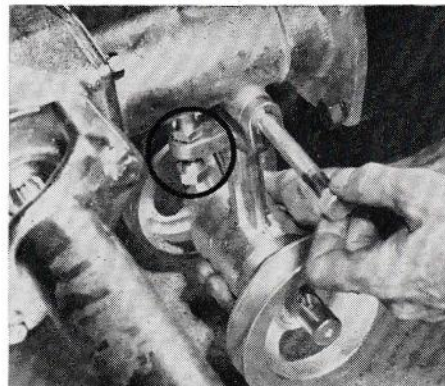

Figure 20

2. Loosen the set screws and remove the Outer Drive Pulley, 1 in Figure 21.

3. Loosen the Bearing Cap Screw, 2 in Figure 21, and pull the Outer Cross Shaft, 3 in Figure 21, out as far as possible so there is room to insert the Inner Wing Drive Pulley and Belt into the opening, 4 in Figure 21.

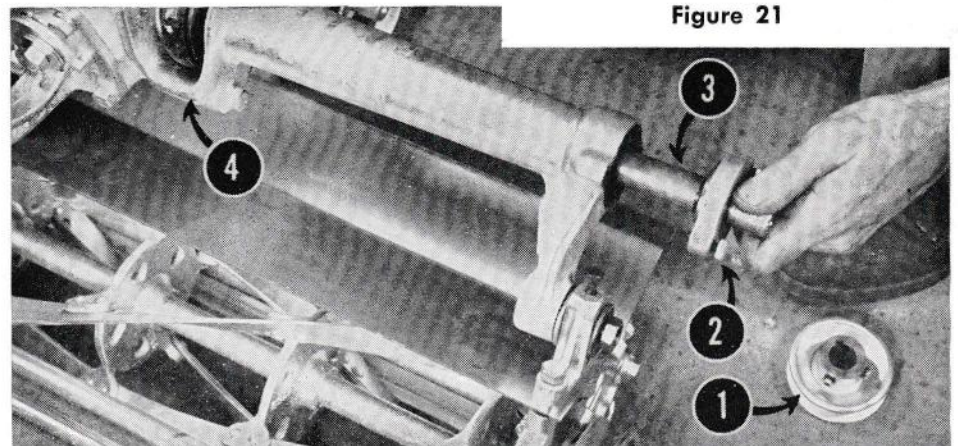

Figure 21

4. Replace the Outer Cross Shaft, engaging it with the Inner Drive Pulley and tightening the set screw on this Pulley. Replace all parts.

Next attach the Leader, 1 in Figure 22, as follows:

1. Remove the top Tie Rod Bolt, 5 in Figure 19, replacing it with the Leader Pivot and Stud, as shown in Figure 22.

2. Attach the Leader Swivel to the Leader Pivot by using the Leader Swivel Pin, 2 in Figure 22. On new equipment, the Leader Swivel Pin may not fit easily because of paint on the Pin and inside the holes into which it fits. Use fine emery paper to remove the paint.

Finally, attach the Universal Assembly, 1 in Figure 23, as follows:

1. Place the Wing Spider, 2 in Figure 23, in position against the Reel Bearing. Tighten the set screws.

2. Grasp the Locking Ring, 3 in Figure 23 (pulling back against its spring), and place it against the Lower Take-off Shaft, lining up the Locking Ring balls with the holes in the Shaft.

3. Release the Locking Ring to lock the Universal Assembly securely in position against the Power Take-off.

### ADJUSTMENTS AND LUBRICATION.

With the following exceptions, all adjustments and lubrication of the Gang Units are the same as for the 30-inch Reel Mower:

**BELTS.** Belt tension is adjusted by the Belt Adjusting Screw and lock nut, circled in Figure 20. To increase tension, loosen the Lock Nut and turn the Adjusting Screw clockwise; to decrease tension, turn the Adjusting Screw counter-clockwise. When proper tension is

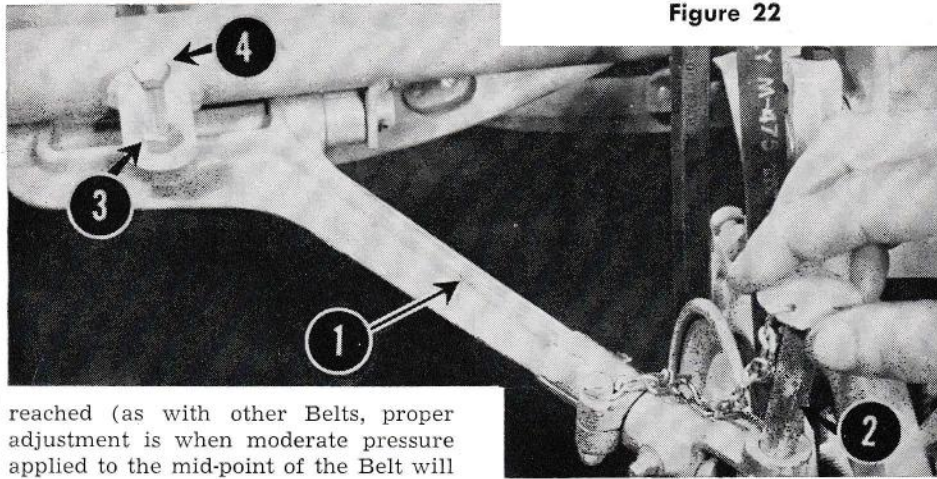

Figure 22

reached (as with other Belts, proper adjustment is when moderate pressure applied to the mid-point of the Belt will

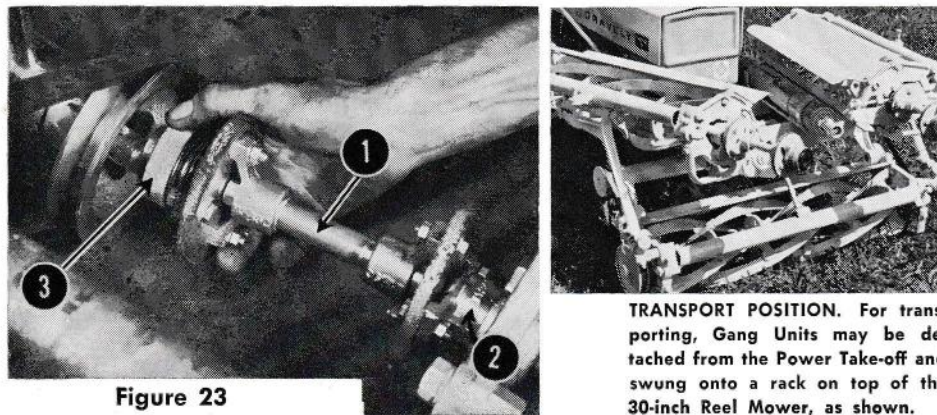

Figure 23

**TRANSPORT POSITION.** For transporting, Gang Units may be detached from the Power Take-off and swung onto a rack on top of the 30-inch Reel Mower, as shown.

deflect it approximately one inch) tighten the Lock Nut.

**LEADERS.** For best results adjust the Leaders so the Gang Units will run parallel with the 30-inch Reel Mower.

**CUTTING HEIGHT.** To adjust the

cutting height, loosen the lock nut, 3 in Figure 22, and turn the Height Adjusting Screw 4, in Figure 22, clockwise (to increase cutting height) or counter-clockwise (to lower cutting height). Tighten the lock nut when proper adjustment is reached.

## SICKLE MOWER

The Sickle Mower is a rugged, dependable mower that makes the toughest weed and brush cutting easy. Swivel action allows the Blade to follow the ground contour to insure a clean cut.

Blades longer than the standard 42 inches are available from your Gravely dealer. Blades are provided with three-inch sections for heavy mowing and two-inch sections for finer mowing.

Using the Dual Wheels or Extension Axles, the Sickle Mower can cut slopes as steep as 60 per cent.

### LUBRICATION

Check the Drive Assembly oil level every four hours of operation by removing the Oil Level Plug, 1 in Figure 24. If oil runs out, the oil level is all right; if not, oil must be added.

To add oil, remove the Oil Filler Plug,

2 in Figure 24 and pour oil through the Oil Filler Hole until oil begins to run out the Oil Level Hole. Replace both Plugs before mowing.

Use SAE 140 in the Drive Assembly.

To lubricate the Universal Joint, remove the Grease Plug, 3 in Figure 24, and fill about half-full with General Purpose Grease.

### ADJUSTMENTS

To insure satisfactory performance, perform the following adjustments as required:

**BOLTS.** Although the Sickle Mower is built and balanced carefully, it is still subject to some vibration. Periodically tighten all nuts and bolts, doing this at more frequent intervals when doing heavy cutting. **Note:** The Gravely Triple-Purpose Wrench, available from your Gravely dealer is required for the Actuating Lever Nut.

**CLIPS.** The Clips which hold the Knife to the Guide Bar should be adjusted frequently to prevent cut matter from "bunching" and causing improper feed-off. When in proper adjustment, the Clips should allow the Knife to slide back and forth easily (with the pressure of a finger and thumb). The Clips should hold the Knife in firm contact with the Shear Plates, but should not cause binding. To adjust, knock the Clips down gradually with gentle taps from a light hammer.

**SWIVEL ACTION.** To increase swivel action (allowing the Mower to follow the contour of the ground), loosen the bolts, 6 in Figure 24. When these bolts are tightened firmly, the Mower is held in a rigid position. The bolts should be tight enough so the Guide Bar will hold its position until lowered, but loose enough for the Guide Bar to follow the contour of the ground.

**GUARDS.** Always keep the Guards, 7 in Figure 24, in alignment by tapping these with a light hammer until the Knife Sections lie flat on the Shear Plates of the Guards. Keep the Guard Bolts tightened securely.

### CARE OF THE KNIFE

For best performance, keep the Knife Sections sharp. To remove the Knife for sharpening, remove the Knife Bracket Screws, 5 in Figure 24, and slip the Knife out either side. Grind the Knife Sections along the same bevel as ground originally. When replacing the Knife, make sure the Knife Bracket Screws are tightened firmly.

**Note:** It is good practice always to have an extra Knife, already sharpened, which you can put on the Mower when needed. This way you can always have a sharpened Knife in reserve.

No lubrication is required for the Knife while in operation, as juices from weeds and grass will furnish sufficient lubrication. However, to prevent rust, wipe the Knife and Guide Bar with a thin coat of light oil after operating. When the Mower is to be stored for any period of time, clean it thoroughly and apply General Purpose Grease to all unpainted parts.

### OPERATING HINTS

Always mow at a normal walking speed with the Tractor in low gear. Excessive speed will exaggerate the Mower vibration, causing nuts and bolts to become loose much faster than normal.

• If excessive vibration is encountered, check to see if the Wearing Tip (on the end of the Actuating Lever) is worn or missing, or if the Bracket is

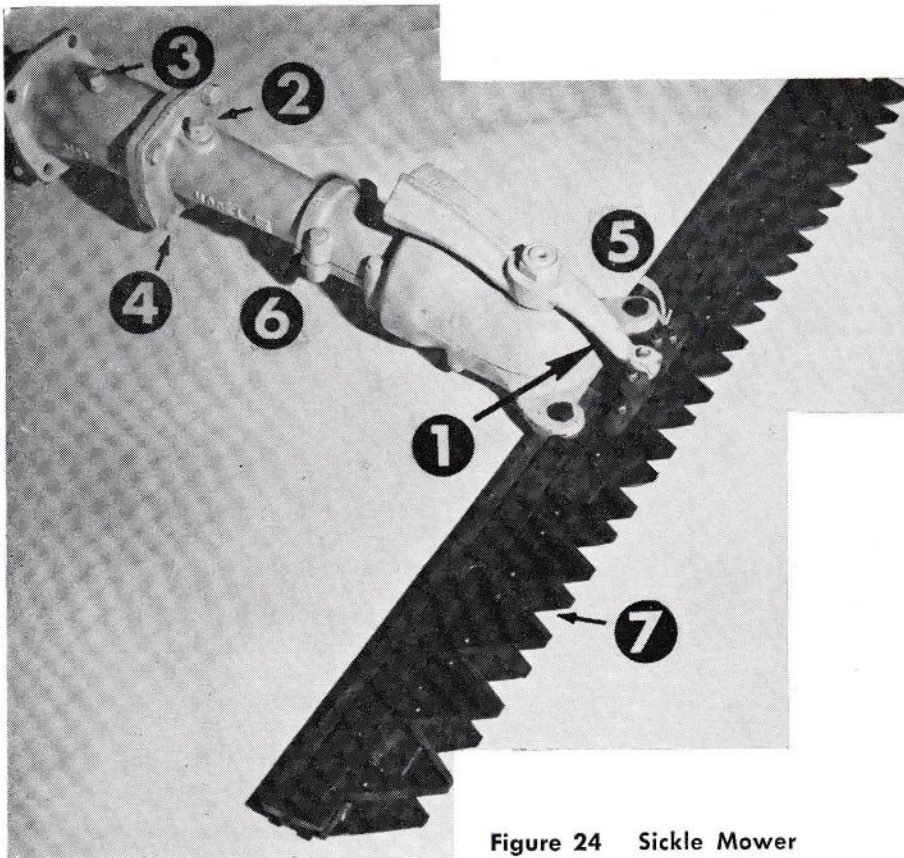

Figure 24 Sickle Mower

worn badly; if so, your Gravely dealer can replace these parts for you.

- If cut grass or weeds begin collecting on the Mower instead of feeding-off properly, check the alignment of the Guards and Knife Sections, as well as sharpness of the Knife Sections.

- If this does not correct the improper feed-off, make sure one end of the Mower is not dragging up already-cut material. This is the result of taking too small a "bite."

- Another cause of improper feed-off is a rusty or gummy Mower. Always keep it clean.

- Finally, the improper feed-off may be caused by improper adjustment of the Safety Clutch.

### CAUTION

Never attempt to clear the Mower, or make any adjustment whatsoever, unless the attachment is out of gear and stopped, and the Tractor Engine is stopped.

- Never handle the attachment by any cutting surface. Keep hands away from Knife Sections. Grasp the Mower by its Drive Column and other non-cutting surfaces to carry it.

- Try to keep clear of rocks and debris, as these will damage the cutting surfaces.

### SKIDS

Skids which fit under the Guide Bar are available from your Gravely dealer. For most mowing, these Skids are not necessary; however, you may want these for certain jobs, such as mowing pastures in which you wish the grass to grow and only the tall weeds to be cut.

Your Gravely dealer will provide you with instructions for installing the Skids on your Sickle Mower.

## SNOWBLOWER MA-210, 26" AND 211, 34"

### LUBRICATION

All major bearings of the MA-210 and MA-211 Snowblower that require lubricant are permanently lubricated, or are lubricated from the tractor transmission. However, the operator should check the oil level in the gear box by removing the upper pipe plug. Oil should come up to the bottom of this hole. If the oil level should ever be low, add worm type gear lubricant as recommended for truck worm-gear axles in your area. See Figure 25.

1. Oil Level and Fill Plug.
2. Drain Plug.
3. Clutch Adjusting Nut.

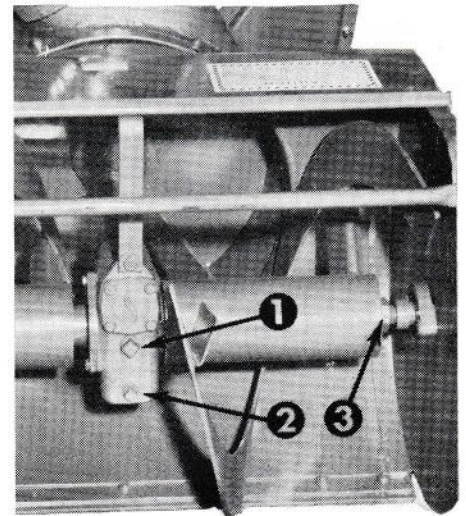

Figure 25  
ATTACHING

The Snowblower Drive housing mounts to the front of the tractor with two nuts and two bolts, the same as other Gravely power Attachments. The chute control crank should be attached to the top sprocket housing shaft of the Snowblower with the rubber connector and two (2) clamps which are provided. See Figure 26

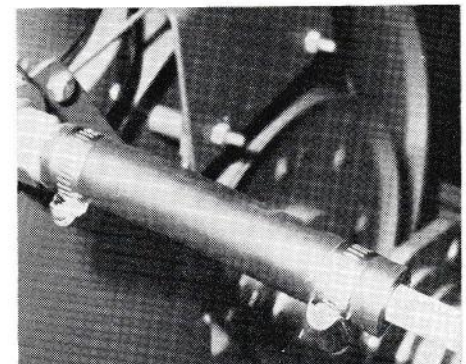

Figure 26

The crank should then be mounted to the tractor left-driving handle with the crank support and crank support clamp.

**Note:** If the Snowblower is uneven with the ground after mounting on tractor, adjust the air pressure in the tractor tires.

### ADJUSTMENTS

**DISCHARGE CHUTE.** To position the Discharge Chute, turn the control crank. The Discharge Chute will rotate approximately 165 degrees from extreme left, through the vertical position, to the extreme right. As the crank is turned the deflector opening is also rotated from the extreme left position through a forward position approximately 180 degrees to the extreme right position.

**DEFLECTOR.** To provide accurate placement of the blown snow near the blower on either side or forward throw, loosen the large wing nut on the deflector and adjust the deflector position.

**SKIDS.** To raise or lower the Snowblower cutting edge, first disengage the power take-off and stop the tractor engine. Then loosen the skid mounting bolts and slide the skids up or down as desired, and tighten the skid mounting bolts securely. This adjustment can be made more accurately if the cutting edge is placed on blocks while the adjustment is made.

**REEL CLUTCH.** The Reel Clutch is properly adjusted at the factory. If it should become necessary to tighten the protective friction clutch in the reels, turn off the tractor engine, disengage the power take-off, and block the rotation of the fan. Now tighten the large nut on the left end of the reel shaft (as viewed from the rear of the Snowblower). See Figure 25.

The nut should be tightened to 85 to 95 lb. feet of torque. This would be 90 lbs. force at the end of a 12 inch wrench, or 72 lbs. at the end of a 15 inch wrench, or 60 lbs. at the end of an 18 inch wrench. Over-tightening can cause damage to the Snowblower.

**CONTROL SHAFT CLUTCH.** The fan housing is prevented from rotating by a small friction clutch on the top sprocket housing shaft, except when the control crank is turned by the operator. The resistance of the clutch may be varied by adjusting the nut on the top sprocket housing shaft. Adjust the nut so that it is just tight enough to prevent the fan housing from rotating during operation of the Snowblower except when the fan housing is rotated by the control crank.

### ACCESSORIES

A special Accessory Kit is available which includes:

**DRIFT CUTTERS.** Two Drift Cutters are provided. These mount inside the reel housing ends and extend upward to slice through snow up to 30 inches deep. The Drift Cutters are flared to assist in turning in deep snows. No adjustment is necessary. Figure 27

**CASTERS.** Two caster weldments and mounting brackets are included. These bolt to the inner sides of the frame and may be used in place of the skids.

The caster bracket holes are slotted, and three (3) pairs of holes are provided in the frame for height adjustment. Figure 28

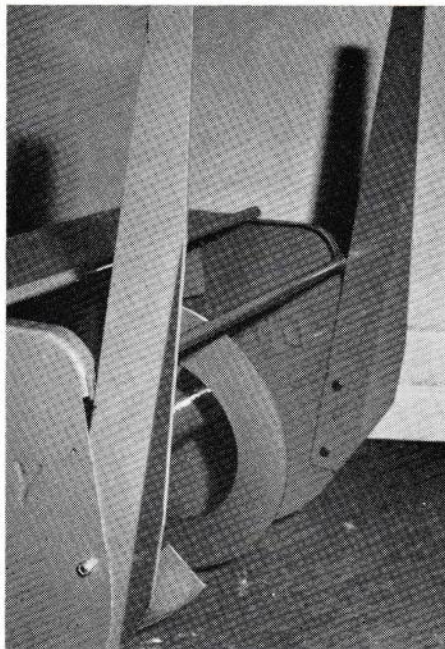

Figure 27

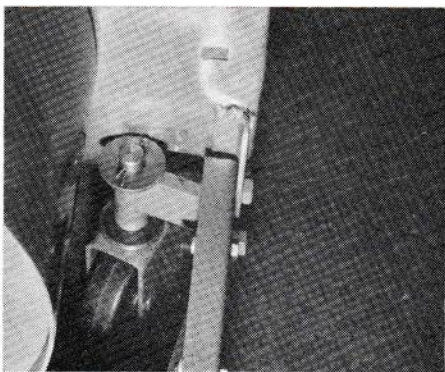

Figure 28

### SAFE SNOW REMOVAL IS NO ACCIDENT

Improper use of snow removal equipment on the part of the operator can result in injury. To reduce this possibility, give complete and undivided attention to the job at hand.

Protect yourself and others by following these safety tips:

1. Stop motor before removing obstacles, making adjustments (except with the control crank), or when leaving the operating position.

2. Disengage the power take-off and wait till the fan stops before adjusting the Deflector. Never direct discharge at bystanders, or allow anyone in front of machine—debris may be hidden in the snow.

3. Keep children and pets a safe distance away.

4. Do not allow children to operate machine, nor allow adults to operate it without proper instruction.

5. Adjust height to clear gravel or crushed rock surface.

6. Exercise caution to avoid slipping or falling, especially when operating in reverse.

7. Know the controls and how to stop quickly.

### POWER BRUSH

The Power Brush is a useful tool for cleaning parking lots, drives, sidewalks, and other areas where power sweeping is necessary. The Brush can be used for sweeping light snows—up to six inches in depth—clean to the pavement unless there is an ice skim on the pavement.

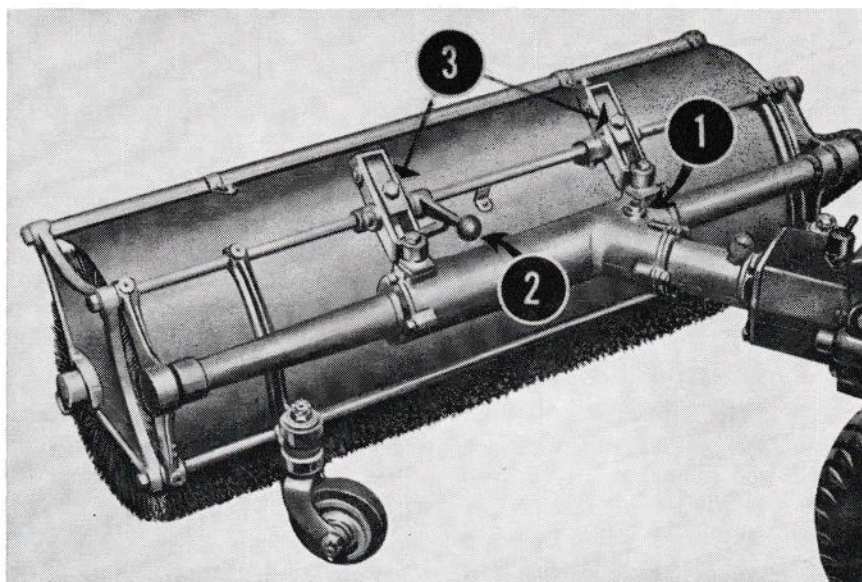

Power Brush

Figure 29

## LUBRICATION

Check the Drive Assembly oil level every eight hours of operation by removing the Oil Filler Plug, 1 in Figure 29, and observing whether the gears dip halfway in the oil.

Add oil, if necessary, through the Oil Filler Hole. Use SAE 140.

Be sure the Tractor and Brush are level when checking or adding oil.

Use General Purpose Grease in the grease fitting (or grease cup) on the Drive Assembly (this is close to the point where the Drive Assembly is attached to the Tractor).

## ADJUSTMENTS

To adjust the Chains, simply remove a half link when the Chain has been driving long enough to "stretch." This usually occurs after several months of use.

To adjust Brush contact, put the Brush in contact with the ground by lifting up on the Brush Contact Lever, 2 in Figure 29. Then turn the Brush Tension Adjusting Bolts, 3 in Figure 29, until proper tension is reached.

Proper Brush tension must be learned by experience. The Brush, of course, must be placed under sufficient pressure to enable it to sweep clean. Always adjust Brush tension downward until correct tension is obtained. **Note:** Too much pressure will cause the Brush Strips to wear out prematurely.

## REVERSING OR CHANGING BRUSH STRIPS

When it appears the Brush Strips have worn more on one side than on the other, it is time to reverse the Strips in the Brush Spiders. To do this, loosen the bolts which hold the Strips in the Spiders and remove the Strips. Then reverse the Strips (or replace, when necessary, with new Strips obtained from your Gravelly dealer) and tighten the bolts. Adjust to proper tension following procedures outlined above.

## TRANSPORTING THE BRUSH

To save unnecessary wear on the Brush strips when going to or from a job, push down on the Brush Contact Lever to raise the Brush off the ground.

Brush life will be increased greatly by wetting the Brush Strips before use, and keeping them wet during prolonged use.

## 48-INCH SNOWPLOW

The 48-inch Snowplow clears the average walkway in one pass, the average driveway in two. It moves snow as deep as 18 inches. Key to its efficiency is its unique design—instead of pushing the snow, the Snowplow rolls it out of the way.

The Snowplow has many uses in addition to removing snow. These are discussed under "Additional Uses."

**ADJUSTMENTS.** The current Snowplow has a Swivel Casting (the Swivel Casting is the part which is attached to the front of the Tractor) which has three holes in it. The Snowplow can be adjusted so there is swivel action, allowing the Blade to follow closer the ground contour, or it can be set so the Blade is held rigidly.

To set the Snowplow to roll straight ahead with swivel action, line up the center hole in the Swivel Bracket with the center hole in the Swivel Casting and insert the T-shaped Adjusting Pin. To hold the Blade rigidly in the straight-ahead position, insert the Pin in the holes on either side of the center holes.

To roll snow to the left with swivel action, line up the left (left, as you stand at the Handles) hole in the Swivel Bracket with the center hole in the Swivel Casting and insert the Pin. To hold the Blade rigidly in the left position, insert the Pin in the holes immediately to the right.

To roll snow to the right with swivel action, line up the right (right, as you stand at the Handles) hole in the Swivel Bracket with the center hole in the Swivel Casting and insert the Pin. To hold the Blade rigidly in the right position, insert the Pin in the holes immediately to the left. To replace, simply remove the screws, take off the old Strip, put the new Strip on, and tighten the screws firmly.

**SKIDS.** Skids, available from your Gravelly dealer, are useful when working on concrete drives where one side is higher than the other (thus forming an edge which would catch the Blade) and on gravel or bluestone drives to keep the Blade high enough to remove the snow without removing the gravel or stone.

To attach the Skids, remove the end screws from the Wearing Strip and insert the long bolts provided with the Skids. Slip the Skids onto the bolts from the rear of the Blade, with the long sides down and parallel to the ground. Fasten the nuts securely on the bolts.

**RECOMMENDED ACCESSORIES.** Gravelly Tire Chains are helpful when removing snow from ice-coated pave-

ments. When using the Snowplow for light bulldozing, the Dual Wheels in many cases may be desirable.

**LUBRICATION.** No lubrication is required.

**ADDITIONAL USES.** The Snowplow is used by many landscapers in combination with the Rotary Plow and Rotary Cultivator to prepare lawns for seeding. After plowing, the Snowplow can be used to terrace and grade. Many users go over the area to be seeded with the Tractor in reverse, so that the Snowplow follows the Tractor. This makes a smooth, even seedbed properly prepared for seeding. In some cases, after seeding the Snowplow is used in the same manner, thus setting the seeds at approximately the right depth for good germination.

- Owners of motels, parking lots, and drive-in theatres use the Snowplow in reverse to level gravel and slag driveways.

- Industrial users employ the Snowplow in unloading bulky materials (such as sand and gravel) from barges. After the clamshell has unloaded most of the material, the Tractor and Snowplow can be lowered into the barge to scrape up the remaining material into piles large enough for the clamshell to pick up.

## 20-GALLON SPRAYER

The 20-gallon Sprayer can be used for all types of spray material. Depending on the type of Disc used in the Spray Gun, the Sprayer has a maximum horizontal throw of 48 feet, and a maximum vertical throw of 34 feet.

### LUBRICATION

No lubrication is required.

### ATTACHING

The Sprayer is attached to the front of the Tractor by two nuts and two bolts, as are all other power attachments. In attaching, loosen the Adjusting Handles on the Sprayer Tank Stands until the Stands are the approximate height necessary to attach the Tractor. After attaching, raise the Stands fully and lock the Adjusting Handles.

### CHANGING NOZZLES

The Spray Gun is delivered with one disc already inserted. To change discs, simply unscrew the Nozzle Cap, remove the Disc, and replace with the desired Disc (orifice) or T-Jet. **Note:** When using the T-Jet, the Gun must be attached to the Tank by means of the Tank Gun Clamp, and the two openings in the T-Jet must be parallel to the ground.



## OPERATING INSTRUCTIONS

See the table on Page 15 for data about application rates of the various Discs, and patterns to be expected using these Discs, at various settings. It is important that the proper Disc (orifice) and Gun setting be used to suit the job, and that proper pressures are used. We recommend you study these data before beginning to spray. Select proper Disc and insert in Nozzle.

**LOADING THE TANK.** Remove the Lid and fill the Tank with the desired solution. Before loading check the Strainer for cleanliness.

Do not become concerned over a small amount of spillage from the vent in the Lid—the vent must be open for efficient operation. Any spill you obtain will be negligible.

**OPERATING THE SPRAYER.** Loosen the locknut, #1 in figure 30, on the handle of Pressure Relief Valve. Turn the handle counter-clockwise approxi-

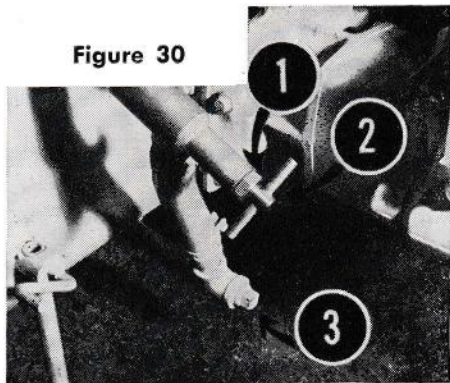

Figure 30

mately ten turns. Close the Gun by turning the handle clockwise. Start the tractor engine with the Attachment Clutch Control in the "out" position. Engage the attachment by operating the Attachment Clutch Control. Set the throttle between  $\frac{1}{4}$  and  $\frac{1}{2}$  open. NEVER OPERATE AT MORE THAN HALF THROTTLE. Engage low gear by operating the inside operating lever. NEVER OPERATE SPRAYER IN HIGH GEAR.

**SETTING PRESSURE.** With Sprayer and Tractor operating, open the Gun by turning the handle counter-clockwise until desired spray pattern (cone or stream) is obtained. Begin adjusting pressure by turning the handle of the Pressure Relief Valve clockwise until you obtain the desired output for the application.

**USING THE SPRAY GUN.** The large Handle on the Gun controls the shape of the spray pattern, either a cone-shaped or a jet-shaped spray. Adjust to suit your job requirement. See Figure 31 for parts of the Gun.

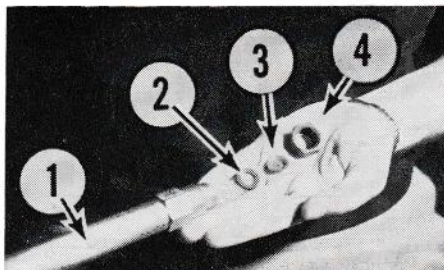

Figure 31

1 Gun; 2 Rubber Washer; 3 Disc; 4 Nozzle Cap.

As mentioned previously, the Discs control the application rate in combination with the pressure. The Discs (Orifices) also control the "throw" of the Spray, with the larger Discs giving greater distance and a more concentrated pattern. For example, if you wish to spray a tall fruit tree, use the Disc with the largest opening, pressure as recommended and the Gun adjusted to the jet-type spray.

## POST-SPRAYING PROCEDURES

Drain all material from the Tank by removing the Drain Plug, 3 in Figure 30. Spray materials can be drained into a suitable container for storage.

After draining, replace the Drain Plug, and fill the Tank with five to 10 gallons of clean water. Start the Sprayer and begin spraying. Using the Gun, you can clean the outside of the Sprayer and by inserting it inside the Tank, you can wash the Tank interior thoroughly.

Continue flushing, refilling if necessary, until the Tank and Gun are clean. Then remove the Drain Plug again, drain, and replace.

Clean the Strainer at this time, by removing the wing nut, 1 in Figure 32. Then hold the Strainer, 2 in Figure 32, under a faucet and flush it with clean water from the inside out.

## DRAIN PUMP IF IN DANGER OF FREEZING

In cold weather—when a freeze is anticipated—always drain the Tank, connections, and Pump.

To drain the Pump, remove the Drain Plug from the T-Joint, remove the clamp from the Pump end of the Pump-to-

Tank Hose, and hold down to drain. (Some Sprayers have the Hose replaced by a pipe and fittings. For these, remove the Drain Plug from the T-Joint at the same location.) Loosen the lock nut

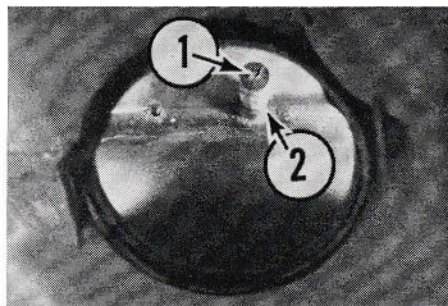

Figure 32

from the Pressure Relief Valve and turn the Valve counter-clockwise 5-10 turns.

Next, loosen, but do not remove, the Pump Caps. Loosen the bolts only until the Cap will come out about  $\frac{1}{8}$ -inch. Both Caps should be treated this way. After draining is completed, replace the Caps and all connections and plugs.

## CAUTION

Spraying compounds usually are poisonous. Take the manufacturer's recommended safety procedures at all times, both in handling and spraying and in protection of by-standers, particularly children and animals. Do not allow children to operate the Sprayer, and keep it and all spraying materials out of their access.

## HINTS FOR EASIER OPERATION

Be sure the apertures in the Discs and T-Jet are kept clean. Also, be sure the Strainer is kept clean. If these become clogged, the Sprayer will not produce a spray from the Gun.

- After using a corrosive or abrasive spraying compound, make sure the entire Sprayer is cleaned thoroughly, both inside and out. Doing this will add to the life and satisfactory performance of the Sprayer.

- If a leak in the plumbing develops, try to tighten slightly. If this doesn't work, replace the offending parts. Do not overtighten the connections—use minimum pressure to set these securely.

Any other malfunction of the Sprayer should be called to the attention of your Gravely dealer, who has the parts, tools, and knowledge to service it quickly and efficiently.

### CONDENSED SPRAY GUN DATA

(All ratings taken at maximum pressure, 300 psi)

Disc	Maximum Stream Throw		GPM	Maximum Angle of Spray		GPM
	Horizontal	Vertical		Horizontal Throw	Vertical	
D-2	35'	24'	.94	10.5'	17	.90
D-4	39'	30'	1.90	11.0'	20	1.80
D-6	48'	34'	4.10	11.0'	33	3.80

T-JET: Gives fan spread of approximately 8-10', yields .47-1.64 GPM depending on pressure (which can be set from 25 psi to recommended maximum of 300 psi).

## TWIN-TOOL POWER ROTARY PLOW AND ROTARY CULTIVATOR

### ROTARY PLOW

The Rotary Plow is attached to the Tractor by four bolts. Two bolts must be used to attach the Angle Adjusting Bracket, upper left in Figure 33.

#### LUBRICATION

Check the Gear Housing oil level every eight hours of operation. Gear Housing oil capacity is 1½ pints. Use SAE 140.

Add oil by removing the Oil Filler Plug, 1 in Figure 33.

To drain old oil, loosen the Angle Adjustment Bolt (which fits in the Angle Adjustment Bracket) and turn the attachment upside down. Remove the Oil Filler Plug.

Replace the Oil Filler Plug after new oil has been put into the Gear Housing.

Use an occasional shot of General Purpose Grease in the swivel casting grease fitting, 2 in Figure 33.

#### DEPTH OF CUT ADJUSTMENT

Use the pin or clip, 3 in Figure 25, in the Hex Shaft for initial cutting depth adjustment. The higher on the Shaft the Pin is inserted, the lower the depth of cut and vice versa. Ordinarily, the Pin is inserted in the topmost hole for plowing and in the bottom hole for transporting.

A final cutting depth adjustment, if required, is made by sliding the Wheel Bracket Clamp, 1 in Figure 34, up or down in the slotted Wheel Bracket. The lower the Clamp is set, the lower the depth of cut.

#### PLOWING ANGLE ADJUSTMENT

When plowing for the first time, set the Plow at the approximate angle to the ground as shown in Figure 34. The nut which secures the Angle Adjustment Lever must be loosened to do this; be sure it is tightened firmly after the proper angle is set.

If there is excessive drag to the left (left, as you stand at the Handles) move the Plow in the direction of the arrow in Figure 34. If there is excessive drag to the right, move the Plow opposite the direction of the arrow.

A few trials may be required before the Plow is adjusted properly to soil conditions.

#### WIDTH OF CUT ADJUSTMENT

The width of cut is governed by the position of the Wheel Bracket in relation to the Depth Wheel in the furrow. The closer the Wheel Bracket is to the Depth Wheel in the furrow, the narrower the cut, and vice versa.

#### DIRT SHIELD

The optional (at no extra cost) Dirt Shield is attached to the top of the Gear Housing by removing the bolts, 4 in Figure 33, inserting them through the Shield, and replacing in the Gear Housing. You can use the Dirt Shield to direct the throw of the dirt, by bending it up or down.

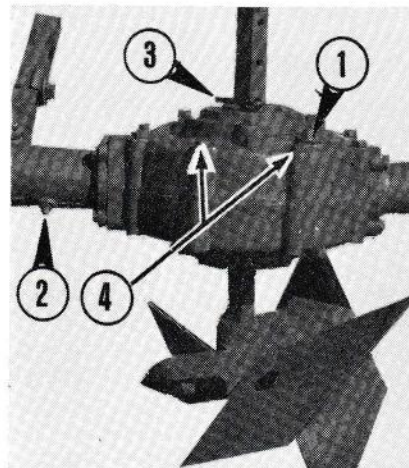

Figure 33

### OPERATING INSTRUCTIONS

To plow your land, first run a furrow down the center of the land to be plowed. Then pivot the Tractor at the end of the furrow so the Right Depth Wheel is in the furrow just made. Continue this way so the dirt is always thrown toward the center (see Figure 35).

If you are plowing a large area, you will be able to "pull" the Tractor around corners without pivoting. However, in small areas it is necessary to pivot the Tractor each time.

Pivoting is made easier by observing the following: When you are ready to pivot, bear down on the Handles until the Tractor is balanced. "Slip" the Clutch gently, holding back on the Right Handle, allowing the Engine to pivot the Tractor with little effort on your part.

Plowing is much easier if the Gear Housing is kept level with the ground when the Plow is in the furrow and plowing. To do this, try to obtain all depth adjustment by the holes in the Hex Shaft, and the horizontal adjustment by moving the Wheel Bracket laterally.

#### OTHER ROTARY PLOW USES

In addition to routine plowing, the Rotary Plow can be used for:

**DITCHING.** Best results are obtained by using the special long Hex Shaft, which is available from your Gravely dealer. Use the Adjusting Handle to turn the Plow at a fairly large angle from the vertical, so the dirt will be thrown from the ditch. Straddle the cut you are making with the Wheels. Make the first pass fairly shallow; on succeeding passes drop the depth of cut lower each time until the desired depth is reached.

**PLANTING TREES AND SHRUBS.** Remove the Depth Wheels and Wheel

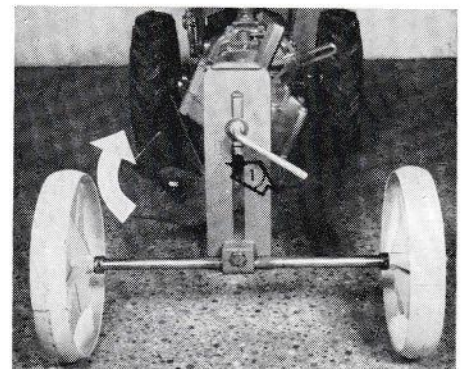

Figure 34

Bracket from the front of the Rotary Plow. Take the Adjusting Handle loose from the Angle Adjustment Bracket and turn the Shaft until it is vertical. Spot the Plow where you want the hole, put the Plow in gear, and let it eat its way down. It prepares a hole suitable for evergreens and other small trees and shrubs.

**MAKING HILLS.** Use the Rotary Plow as follows to make hills for sweet potatoes and other crops: With the Dirt Shield bent downward so the dirt cannot be thrown farther than a foot, make a furrow at the exact location where you want the center of the hill. At the end of this furrow, pivot the Tractor and make a second furrow (the Plow will

throw the dirt to the right, forming one side of the hill). At the end of the second furrow, again pivot the Tractor and make another furrow to the right of the first furrow (the Plow will throw the dirt to the right, forming the other side of the hill).

1. Start.
2. Pivot and set right wheels in first furrow.
3. Pivot and again set right wheels in first furrow.
4. Keep right wheels in each succeeding furrow.

Figure 35

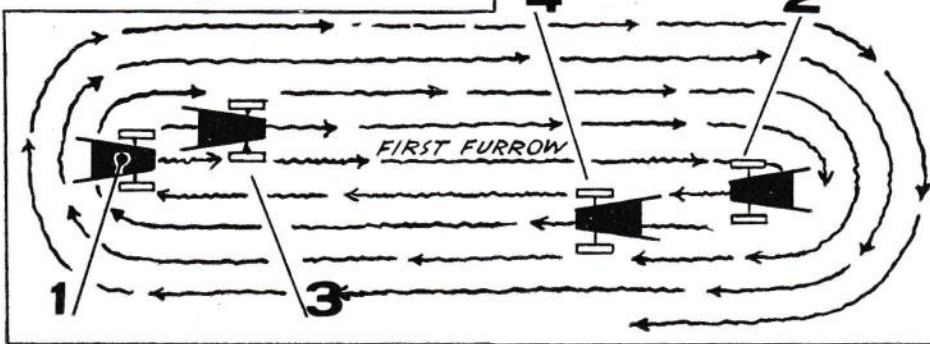

## ROTARY CULTIVATOR

The Rotary Cultivator is attached to the Rotary Plow Drive Assembly as follows:

1. Leave the Plow Angle Adjusting Assembly (upper left in Figure 33) attached.

2. Remove the Hex Shaft (and Plow Blades) from the Gear Housing.

The Depth Wheels, Wheel Bracket, and Column Assembly (which connects the Wheel Bracket to the Gear Housing) may be removed, as these serve no useful purpose unless you wish to operate the Cultivator with the Tines cutting against the motion of the Tractor (see "Operating Hints").

**Note:** After the Column Assembly has been removed, bolts must be inserted into the Gear Housing to prevent oil leakage. We recommend short bolts for this purpose; if the original bolts are tightened, the gears inside the Gear Housing will be fouled. If, however, you use the original bolts, place sufficient washers on them to prevent gear fouling.

3. Rotate the Gear Housing 180° so the Oil Filler Plug is on the bottom. Remove the four bolts from the bottom of the Gear Housing and insert the studs furnished (if you do not have a stud

driver, two nuts may be locked together on the threads and used to seat the studs; remove the nuts after seating the studs).

4. Fit the Hood as shown in Figure 36. Insert the Cultivator Drive Shaft into the Gear Housing.

5. Use the elastic stop nuts to fasten the Cultivator Drive securely to the Gear Housing.

6. Rotate the Cultivator to the position shown in Figure 37. In this position the Tines will cut in the same direction (clockwise) as the forward movement of the Tractor.

7. Install the Dust Shield and Fastener on top of the Hex Shaft.

8. Use the Adjusting Bracket to lock the Cultivator in place with the long axis of the Cultivator parallel to the Tractor Axles.

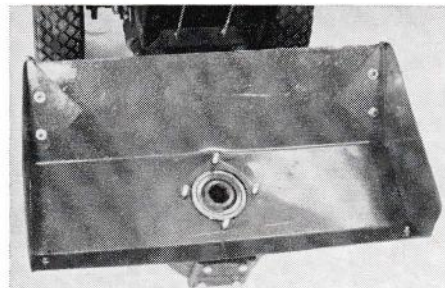

Figure 36

**Note:** The Gravely Triple-Purpose Wrench, available from your Gravely dealer, is required for the Cultivator Tine Shaft Nut.

### LUBRICATION

Check the Cultivator Drive Assembly oil level every eight hours of operation by removing the Oil Level Plug, 1 in Figure 38. If oil runs out the Oil Level Hole, the oil level is all right; if not, oil must be added.

To add oil, remove the Oil Filler plug, 2 in Figure 38, and pour through the Oil Filler Hole until oil begins to run out the Oil Level Hole. Replace both Plugs when proper oil level is reached.

Use SAE 140. Be sure the Cultivator is level when checking or adding oil.

### STORAGE

When the Cultivator is detached from the Drive Assembly, place the small Spacers (cylinders) over the studs and secure in place with the stud nuts.

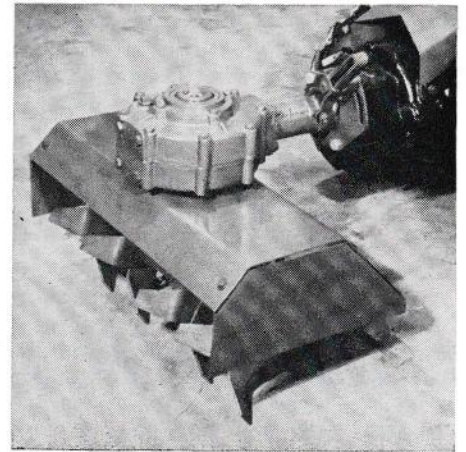

Figure 37

### OPERATING HINTS

The Rotary Cultivator is designed for cultivating soil which has been broken previously. It is not recommended for use as a plow. Use the Gravely Rotary Plow to prepare a perfect seedbed in one operation and the Rotary Cultivator for perfect cultivation throughout the season.

- Cultivating depth is controlled by light pressure on the Handles. When the Tines are set to move clockwise—as they usually are—depth is controlled generally by the design of the Cultivator itself, about three inches.

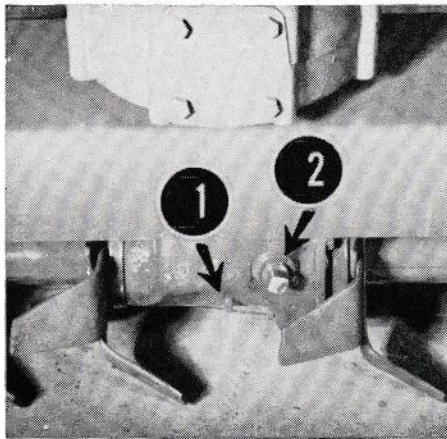

Figure 38

## REAR HITCH INSTRUCTIONS

### LEVELING THE TRACTOR

Sometimes it is necessary to change the relation between the tractor handles and the operator's knees, when using the Rear Hitch. To do this, loosen the lock nuts on the Ball Stud and turn the Ball Stud (with a  $\frac{1}{4}$ -inch Allen wrench) clockwise to raise the Handles (or counter-clockwise to lower the Handles).

**Note:** After this adjustment, be sure the lock nuts on the Ball Stud are tightened securely.

### SPLIT-SOCKET CONNECTION

The Rider requires the Split-Socket Connection. Place the Split-Socket around the Ball Stud. Next, insert the end of the Split-Socket into the hollow Draw Bar on the attachment, lining up the hole in the Draw Bar with the hole in the end of the Split-Socket. Insert the Pin through both holes.

Be sure the nuts on the Ball Stud are locked securely against the cross-mem-

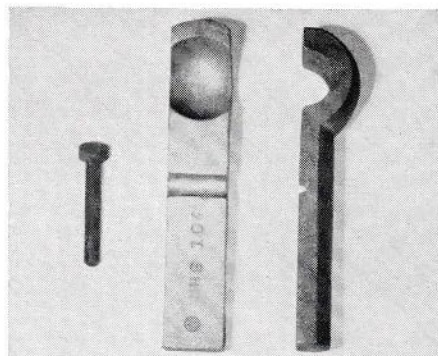

Figure 39

ber. These nuts, rather than the threaded portion of the Ball Stud, absorb

the thrust. Unless both nuts are tightened securely, the threads in the hole in the cross-member may be stripped.

## RIDER

The Gravely Rider lets you guide the Tractor easily while you ride comfortably.

An optional Seat Cushion, made of soft foam rubber and plastic, may be purchased from your Gravely representative.

**ATTACHING.** Split-Socket Connection is required.

**SEAT ADJUSTMENT.** The Seat can be moved forward or rearward to suit your requirements. Simply detach the Seat Spring from the Frame, move it to the desired position, and re-attach it to the Frame by the provided nuts and bolts.

**LUBRICATION.** The only lubrication required is an occasional shot of General Purpose Grease in the grease fittings on the Wheels.

## CONVERTIBLE RIDER

The Convertible Rider must be adjusted on the drawbar to fit the Commercial-10. Cut drawbar off in front of SECOND hold to move operator closer to tractor for convenient operation.

Seat adjusts forward and back with wing nut. Attaching and lubrication same as standard Rider.

## LAWN ROLLER

The Lawn Roller makes easy the job of smoothing out rough places on lawns. It is 32 inches wide, has round edges to prevent lawn damage, and weighs 655 pounds when filled to capacity with water—plenty of weight to press down rough spots, but not too heavy to keep the powerful Gravely Tractor from moving it to practically anywhere you need it.

**ATTACHING TO TRACTOR.** Pin Connection.

**FILLING THE ROLLER.** Move the Roller until the Filler Plug (a large brass plug on the right side of the Roller) is at its highest point. Simply remove the Plug to fill the Roller; be sure it is re-

placed after filling. Water generally is used.

**LUBRICATION.** An occasional greasing of the Axles with General Purpose Grease is the only lubrication required. To lubricate, remove the cotter pin and slip off the large washer. Make sure both are replaced.

## CART

There's always hauling to be done—and with the Gravely Cart you have a rugged, dependable vehicle which can handle a 1,000-pound load.

**ATTACHING TO TRACTOR.** Pin Connection.

**DUMPING.** The Cart is dumped by releasing the Latch which holds the Cart to the Frame and tilting the Cart to the rear.

**LUBRICATION.** The only lubrication required is an occasional shot of General Purpose Grease in the grease fittings on the Wheels.

## 5-FOOT SEEDER-SPREADER

The 5-foot Seeder Spreader is a very useful attachment for seeding large lawn areas, as well as for spreading fertilizer. Its 300-pound capacity and extra width make it an ideal means of seeding or fertilizing large areas.

**ATTACHING TO TRACTOR.** Pin Connection.

**DISTRIBUTION CONTROLS.** To determine the proper distribution of seed or fertilizer, refer to the self-explanatory plate attached to the Hopper. Simply set the Port Lever to the indicated opening to distribute seed or fertilizer properly.

**CARE OF HOPPER ASSEMBLY.** Many materials used in the Seeder-Spreader, especially certain fertilizers, are corrosive. Abrasives also are present. This means the protective paint soon will wear off the Port Assembly and Agitator. To protect these surfaces, wash the Seeder-Spreader thoroughly with water after using and let it dry, preferably in the sun. If you do not intend to use it again within a few days, pour a small quantity of oil along the Port Openings and work the Port Lever back and forth to distribute the oil.

**LUBRICATION.** Use General Purpose Grease occasionally in the great fitting on each Wheel.

# Accessories

## DUAL WHEELS

Dual Wheels are useful in situations requiring extra traction, as in use of the 48-inch Snowplow for bulldozing, hauling heavy loads in the Transportation Cart, and mowing terraces and slopes with Gravely mowing attachments. Dual Wheels allow you to mow slopes as steep as 60 per cent. Dual Wheels always should be used when the Steering Sulky is used.

To attach:

1. Remove the three hex-head cap screws that hold the Wheel Rim to the Tractor.

2. Attach the Spacer to the inside Wheel Rim and Tractor by inserting the three long cap screws provided through the holes in the Spacer. Tighten these screws firmly. Be sure the Spacer recess with the small indentation fits over the inside Wheel's Tire Valve.

3. Use the three short cap screws which were removed initially to attach the outside Wheel Rim to the Spacer.

No lubrication is required.

## TOOL HOLDER

The Cultivator Tool Holder, shown in Figure 41, can be used to hold a variety of cultivating tools.

In addition, the Cultivator Tool Holder is used to hold the 36-inch Scraper Blade.

**ATTACHING TO TRACTOR.** The Tool Holder is attached to the front of the Tractor by two nuts and two bolts. Attachment Clutch Control must be at the OUT position.

**ATTACHING TOOLS TO TOOL HOLDER.** The individual cultivating tool, 1 in Figure 41, is attached to a Shank, 2 in Figure 41, which in turn is attached to the Tool Holder by a Shank Holder, 3 in Figure 41.

The Tool Holder comes from the factory with five Shank Holders. These may be moved to different positions on the Tool Holder, if desired, although this is seldom necessary. Additional Shank Holders may be purchased from your Gravely dealer.

Cultivating tools are divided into two classes — those requiring the one-hole Shank and those requiring the two-hole Shank. With the exception of the Furrowers, Hillers, Shovel Steel, and Turning Shovel, cultivating tools require the one-hole Shank.

To attach a tool to its Shank, simply bolt it in place with the nuts and bolts provided.

To attach the Shank to the Tool Holder, loosen the hexagon-head cap screw in the side of the Shank Holder, slip the Shank into the Shank Holder from the bottom, and lock the Shank in place at the desired position by tightening the cap screw.

**CHANGING TOOLS.** After the Shanks have been attached to the Tool Holder, changing cultivating tools requires only the unbolting of the old tool from its Shank and bolting the new tool on. However, if the new tool re-

quires a two-hole Shank in place of a one-hole Shank, the Shank also must be changed.

**PARALLEL BARS.** The Parallel Bars, 4 in Figure 41, can be adjusted in several ways, depending on the task. Usually it is necessary to detach the Bars from the Depth Wheels to make these different set-ups.

**ADJUSTMENTS.** The Depth Wheels are used to set the depth the cultivating tools penetrate the ground. Facing the Depth Wheels, turn the Handwheels clockwise for deeper cultivation and counter-clockwise for shallower cultivation.

Usually the Depth Wheels provide all the adjustment required. However, if required, the Shanks can be moved up or down in the Shank Holders for additional adjustment.

## LUBRICATION

No lubrication is required.

## SCRAPER BLADE

The Scraper Blade, not illustrated, is useful for small grading jobs, such as smoothing seedbeds and removing light snowfalls from walks and driveways.

It is attached to the Cultivator Tool Holder by one-hole Shanks.

No lubrication is required.

## TIRE CHAINS

Tire Chains are useful when using your Tractor for snow removal, especially when there is a thin glaze of ice under the snow. Tire Chains are easily put on and taken off, and provide the extra traction required.

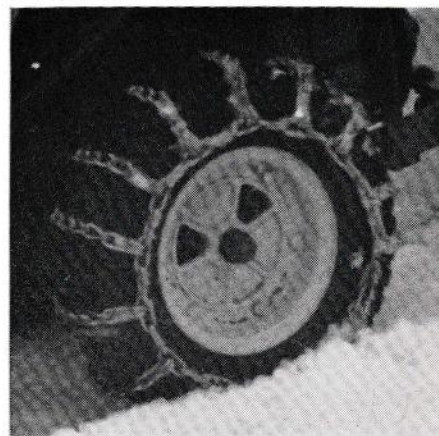
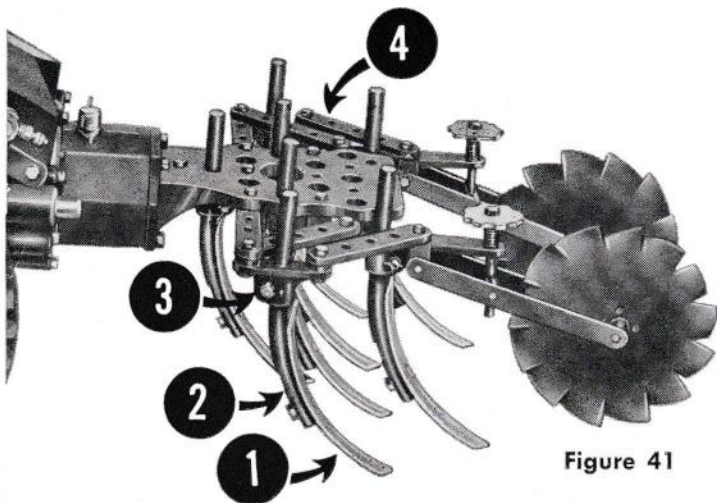



Figure 43

PTO Pulley Diameter	Driven Pulley Diameter								
	4"	5"	6"	7"	8"	9"	10"	11"	12"
4"	1200	960	800	685	600	533	480	436	400
6"	1800	1440	1200	1028	900	800	720	654	600
12"	3600	2880	2400	2057	1800	1600	1440	1309	1200

## POWER TAKE-OFF

The Gravelly Power Take-off can be used to run any equipment which gets its power from a belt and does not require more than 10 HP.

### LUBRICATION

No lubrication is required.

### COMPUTING PULLEY SIZE AND RPM

The table (based on the Power Take-off operating at 1200 RPM in high gear with Engine speed of 2400 RPM—Throttle depressed 1/3) shows RPM generated for various combinations of Power Take-off Pulleys and driven pulleys.

# THANK YOU

for your investment in Gravelly equipment.

It is an investment, for the Gravelly will save you work and worry for many years.

You will gain still greater satisfaction from your powerful Gravelly if you add the tools you need for your other jobs. From time to time we suggest you consult our catalog or this manual for the many Gravelly attachments available.

The Gravelly Commercial Tractor and Attachments are manufactured by Gravelly Tractor Division, Studebaker Corporation. Our main factory is at Dunbar, West Virginia.

Your Gravelly Commercial Tractor and Attachments are warranted under terms shown below.

## Warranty

The Gravely Commercial 10 Tractor and attachments are warranted to be free from defective material and workmanship for a period of ninety (90) days from the date of purchase. All defective parts will be replaced without charge, provided such parts are returned to the Seller, transportation charges prepaid, and in the Seller's opinion, after inspection, are defective, and have not been damaged through neglect, accident or misuse.



GRAVELY LANE—DUNBAR—WEST VIRGINIA—U.S.A.

*A Division of Studebaker Corporation*

# Lubrication and Air Cleaner Check List

## COMMERCIAL-10 TRACTOR

### RECOMMENDED ENGINE OILS (API Service MS)

AIR TEMPERATURE	SINGLE VISCOSITY OIL	MULTIPLE VISCOSITY OIL
Above 30°F.	SAE 30	SAE 10W-30
30° — 0°F.	SAE 10	SAE 10W-30
Below 0°F.		SAE 5W-30

**RECOMMENDED TRANSMISSION OILS.** Summer SAE 30 or SAE 10W-30; Winter (32° F. or below) SAE 20 or SAE 10W-30.

**OIL LEVELS.** Check oil levels daily before starting Engine. Fill to FULL mark on engine dipstick and on transmission dipstick.

**OIL CHANGES.** Change engine oil every 25 hours.\* Change Transmission oil after first 8 hours. Then every 200 hours. Add oil as required to maintain oil level.

**AIR CLEANER.** Inspect every eight hours under normal conditions, every four under very dusty conditions. Clean as required according to directions on air cleaner decal.

### ATTACHMENTS

**GEAR HOUSINGS.** Check oil level of Gear Housings on mowing attachments every four hours. Check oil level of Gear Housings on other attachments every eight hours. Fill to required level with SAE 140 on all attachments except Snowblower; fill Snowblower Gear Housing to required level with worm type gear lubricant as recommended for truck worm gear axles.

**GREASE FITTINGS.** Use General Purpose Grease occasionally on all grease fittings as needed. Once a season minimum.

**PARTS LISTS AVAILABLE  
ON REQUEST**